

OPERATOR'S MANUAL
FOR
MULTIPLE INTEGRATED LASER
ENGAGEMENT SYSTEM
(MILES):
SIMULATOR SYSTEM, FIRING LASER: M63
(NSN 1265-01-077-6082)
FOR
M113 APC
AND M220 TOW VEHICLE

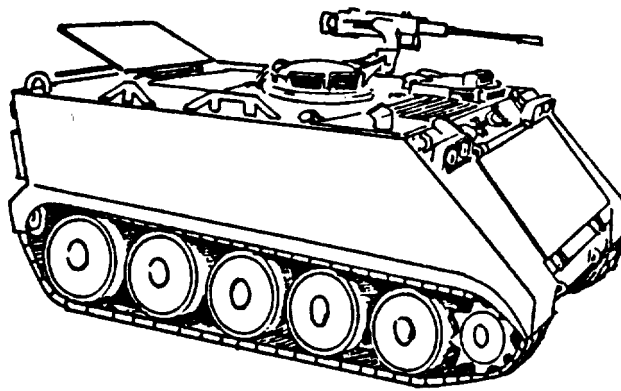

DISTRIBUTION STATEMENT A. Approved for public release; distribution is unlimited.

HEADQUARTERS, DEPARTMENT OF THE ARMY

JULY 1988

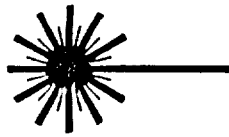

WARNING

**CAUTION 1:
Ear Damage**

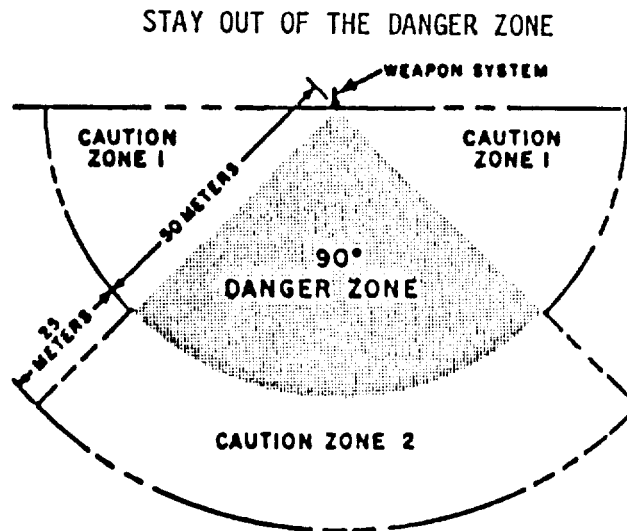

**CAUTION 2:
Flying Debris**

Never stand within the danger zone while loading the ATW ESS. Always stand to the right side of the rear of the launcher. After the cartridge is inserted into the chamber, keep hands, arms, and other portions of the body away from the hole in the center of the breech door. Failure to follow these instructions could result in personnel being burned by the backblast escaping through the hole in the center of the breech door.

Never arm an ATWESS until you are ready to fire.

Treat the TOW/MILES as you would any loaded and armed weapon. Do not drop TOW/MILES when ATWESS is loaded and armed. A strong jolt may set off the ATWESS.

Handle ATWESS cartridges with the same care you use with any live ammunition.

Always wear earplugs when firing the TOW/MILES.

Although the laser light emitted by MILES laser transmitters is considered eye safe by the Bureau of Radiological Health, suitable precautions must be taken to avoid possible eye damage from overexposure to this radiated energy. Take the following precautions:

- Never look at the laser emitter at close range (less than 12 meters).
- Never look at the laser emitter through optics such as binoculars, telescopes, or weapon sights at ranges less than 75 meters.
- Never look at the laser emitter directly along the axis of the bore of the weapon.

Tape mounting primer is highly flammable. Do not spray near heat, sparks, or open flame. No smoking. Use only in well-ventilated areas.

For information on First Aid, see FM 21-11.

OPERATOR'S MANUAL
FOR
MULTIPLE INTEGRATED LASER ENGAGEMENT SYSTEM (MILES)
SIMULATOR SYSTEM, FIRING, LASER, M63
(NSN 1265-01-077-6082)
FOR
M113 APC AND M220 TOW VEHICLE

REPORTING ERRORS AND RECOMMENDING IMPROVEMENTS

You can help improve this manual. If you find any mistakes or if you know of a way to improve the procedures, please let us know. Mail your letter, DA Form 2028 (Recommended Changes to Publications and Blank Forms), or DA Form 2028-2 located in back of this manual direct to: Commander U.S. Army Simulation, Training, and Instrumentation Command (STRICOM), ATTN: AMSTI-LSM, 12350 Research Parkway, Orlando, FL 32826-3276. A reply will be furnished to you.

DISTRIBUTION STATEMENT A. Approved for public release; distribution is unlimited.

TABLE OF CONTENTS

	Page
Storage Instructions	1
Skills Needed to Use This Manual	2
How to Use this Manual	2
General Information	4
Purpose of Equipment	4
Forms and Records	4
Equipment Description	5
Capabilities and Features	5
How It Works	5
Location of Components M113 APC	6
Location of Components M220 TOW	7
How the MILES Equipment is Used	8
Equipment Limitations	8
Task Assignment	9
Install Velcro Tape	10
<u>Outside Tasks:</u>	
1. Inspect Velcro Tape	15
2. Get This Equipment from your NCOIC	16
3. Inspect and Service Detector Belt Segments & Brush Guards	20
4. Install Detector Belt Segments	21
5. Install Brush Guards	22
6. Inspect CVKI	23

*Supercedes TM 9-1265-370-10-3 dated 22 January 1982

7.	Install the CVKI	24
8.	Inspect CVKI Cable Assembly	25
9.	Install CVKI Cable Assembly	26
<u>Inside Tasks:</u>		
1.	Inspect Control Indicator	28
2.	Install Control Indicator	29
3.	Inspect Battery Box	31
4.	Install Battery Box and Batteries	32
5.	Finish Installing Cable Assembly	34
<u>M2 Machine Gun Tasks:</u>		
1.	Inspect and Service M2 Machine Gun Transmitter	36
2.	Put Battery in Transmitter	37
3.	Attach Transmitter	38
4.	Blank-Fire Operation	39
<u>MWLD Tasks:</u>		
1.	Inspect and Clean Torso Harness	40
2.	Inspect and Clean Helmet Harness	41
3.	Install Batteries in MWLD Harnesses	42
4.	Put on Torso Harness	43
5.	Put Helmet Harness on Helmet	44
<u>Test Tasks:</u>		
1.	Test Operation of MWLD	45
2.	Test MILES System	46
<u>Align Tasks:</u>		
1.	Align M2 Machine Gun	49
<u>Operational Tasks:</u>		
1.	Observe Your Target	51
2.	Recognizing Enemy Fire	52
3.	Reset After a "Kill"	53
4.	Turn Off and Reset MWLD Alarm	54
5.	Remove, Inspect, Service and Return all MILES Equipment	55
Appendix A - References		57
Appendix B - Components of End Item and Basic Issue Items List		58
Appendix C - Additional Authorization List		60
Appendix D - Special Tools and Test Equipment		61
Appendix E - Expendable Supplies and Materials List		62
<u>Reference Information:</u>		
Nomenclature Cross Reference List		63
List of Abbreviations		63
Glossary		63

Storage Instructions

Equipment Distribution:

The MILES Equipment for the M113 and M220 TOW vehicle is shown in Task 2 of this Technical Manual (TM). Use the picture with Task 2 as a guide for equipment distribution. Be sure to issue a copy of this TM along with the MILES equipment.

Equipment Return and Storage:

CAUTION

MAKE CERTAIN THAT THE MWLD TORSO AND HELMET HARNESSSES ARE COMPLETELY DRY BEFORE STORAGE IN TRANSIT CASE.

When receiving equipment for storage, always inspect the returned equipment using Operational Task 5 in this TM for guidance.

Return all MILES Equipment and the TMs to their transit cases.

Special Instructions for Infrequently Used Equipment:

If M113-M220/MILES Equipment is unused for 60 days, remove from transit case and perform Outside Tasks 2, 3, 6, and 8; Inside Tasks 1 and 3; Machine Gun Task 1; MWLD tasks 1 and 2; and Operational Task 5.

Skills Needed To Use This Manual

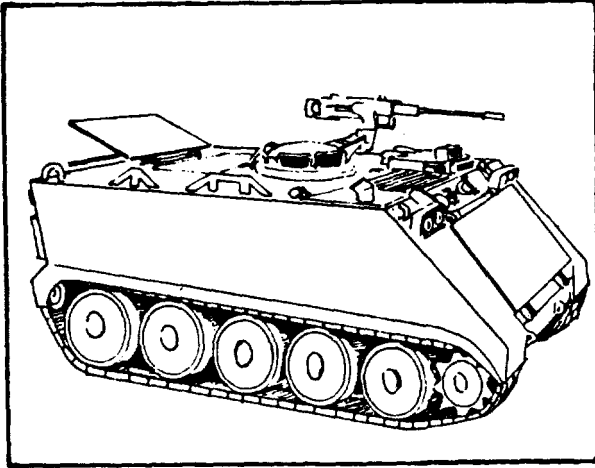

TO USE THIS MANUAL YOU MUST BE ABLE TO:

1. Aim and fire the M2 machine gun. (See TM 6920-43412&P.)
2. Prepare the M2 for blank-fire operation. (See TM 6920-434-12&P.)
3. Complete DA Form 2402.

IF YOU CAN NOT DO THESE TASKS, ASK YOUR NCO OR INSTRUCTOR TO SHOW YOU HOW. WHEN YOU CAN DO ALL THESE TASKS, GO ON WITH THIS MANUAL.

How to Use This Manual

Before you use any M113-M220/MILES equipment, read this Manual

- The first part of the manual briefly explains the purpose of the equipment and how it is used.
- Then comes step-by-step guidance for every task you need to do with the M113-M220/MILES equipment.

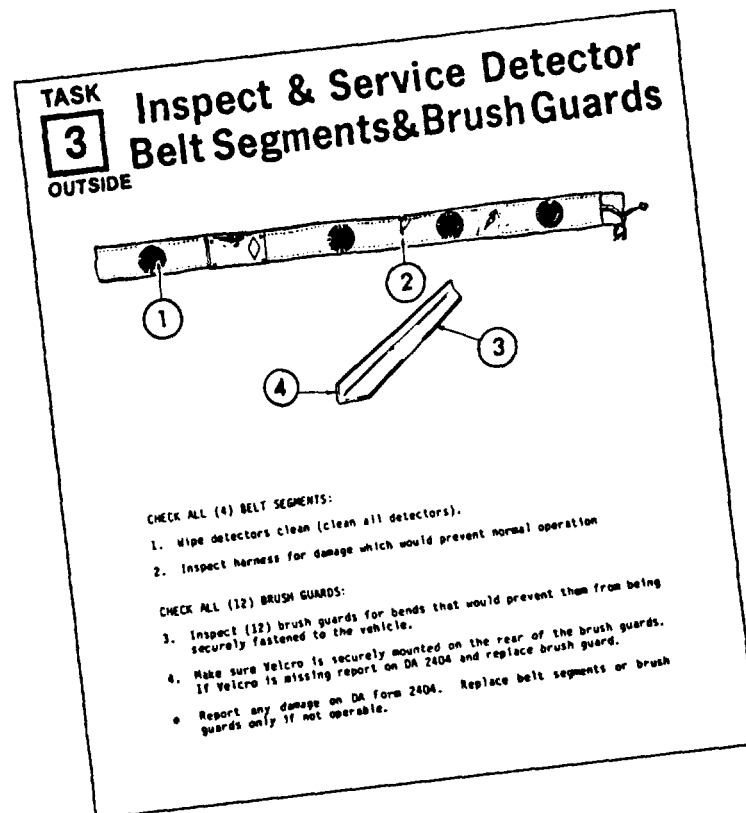

- The task pages look like this. Some longer tasks run more than one page. Before you begin a task, read all the steps in the tasks and look at each drawing carefully. To help perform the task, some steps have matching numbers on the drawings. Perform each step exactly the way you are instructed.
- Do each task in the order it occurs in the manual.

DON'T JUMP AHEAD DON'T SKIP ANY STEPS

- If your equipment has a problem you can't fix using this manual, report it on DA Form 2402. To get a replacement, turn in the faulty equipment and the completed DA Form 2402 to your NCOIC.
- In the back of this manual is a list of abbreviations and an explanation of terms (glossary) used in this manual. If you read a word you don't understand, check the list of abbreviations and the glossary.

General Information

This manual shows you how to operate and maintain the M113-M220 APC/MILES laser simulator equipment. The operator and maintenance tasks are listed in the Table of Contents. For operator and maintenance information pertaining to MILES TOW equipment see TM 9-1265-36810-2.

Purpose of Equipment:

MILES equipment for the M113 APC and M220 TOW vehicle consists of a laser transmitter and a laser detector system. The simulator system allows realistic combat training without the hazards of using live ammunition.

Forms and Records:

- a. Reports of Maintenance or Equipment Replacement. Department of the Army forms and procedures used for equipment maintenance will be those prescribed by DA PAM 738-750.
- b. Reporting Equipment Improvement Recommendations (EIRs).

EIRs can and must be submitted by anyone who is aware of an unsatisfactory condition with the equipment design or use. It is not necessary to show a new design or list a better way to perform a procedure, just simply tell why the design is unfavorable or why a procedure is difficult. EIRs may be submitted on SF 368. Mail direct to: Commander, U.S. Army Armament, Munitions and Chemical Command, ATTN: AMSMC-QAD, Rock Island, IL 61299-6000.

- c. Hand Receipt Manual

Hand receipts for Components and End Item (COE1), Basic Issue Items (BII), and Additional Authorization List (AAL) items are published in a Hand Receipt manual, TM 9-1265-10-3-HR. This manual is published to aid in property accountability and is available through: Commander, U.S. Army Adjutant General Publication Center, 2800 Eastern Boulevard, Baltimore, MD 21220.

Equipment Description

Capabilities and Features:

Major components of the M113-220/MILES System consist of:

1. Laser transmitter mounted on barrel of M2 machine gun, and activated by sound of blank cartridges being fired.
2. Detector belt segments mounted on all four sides of the vehicle hull.
3. A Combat Vehicle Kill Indicator (CVKI) mounted to the engine cover lifting eye. The CVKI is a light which flashes to indicate laser hits on the vehicle.

The M113-M220/MILES system can be operated in temperatures from -35°C (-31°F) to 62°C (144°F). It permits tactical skills to be practiced under realistic conditions.

The laser transmitter sends harmless invisible laser (light) beams toward targets. If the laser beam hits the target, a detector assembly on the target senses the beam, causes an alarm to sound in the intercom of the target vehicle, and causes the externally-mounted light to begin flashing. If the laser beam hits a soldier, a buzzer sounds on the man-worn laser detector harness.

Battery Information:

The M113-M220/MILES system uses BA-200/U, 6-volt carbon-zinc batteries, and BA-3090/U, 9-volt alkaline batteries. These batteries provide approximately 100 hours of power to the system.

How It Works

MILES-equipped weapons work much like the real weapons. However, instead of firing machine gun bullets, the MILES-equipped weapons fire laser light beams at targets. To make the MILES-equipped weapons as real as possible, the machine gun fires blank ammunition.

LOCATION OF COMPONENTS: For M113 APC

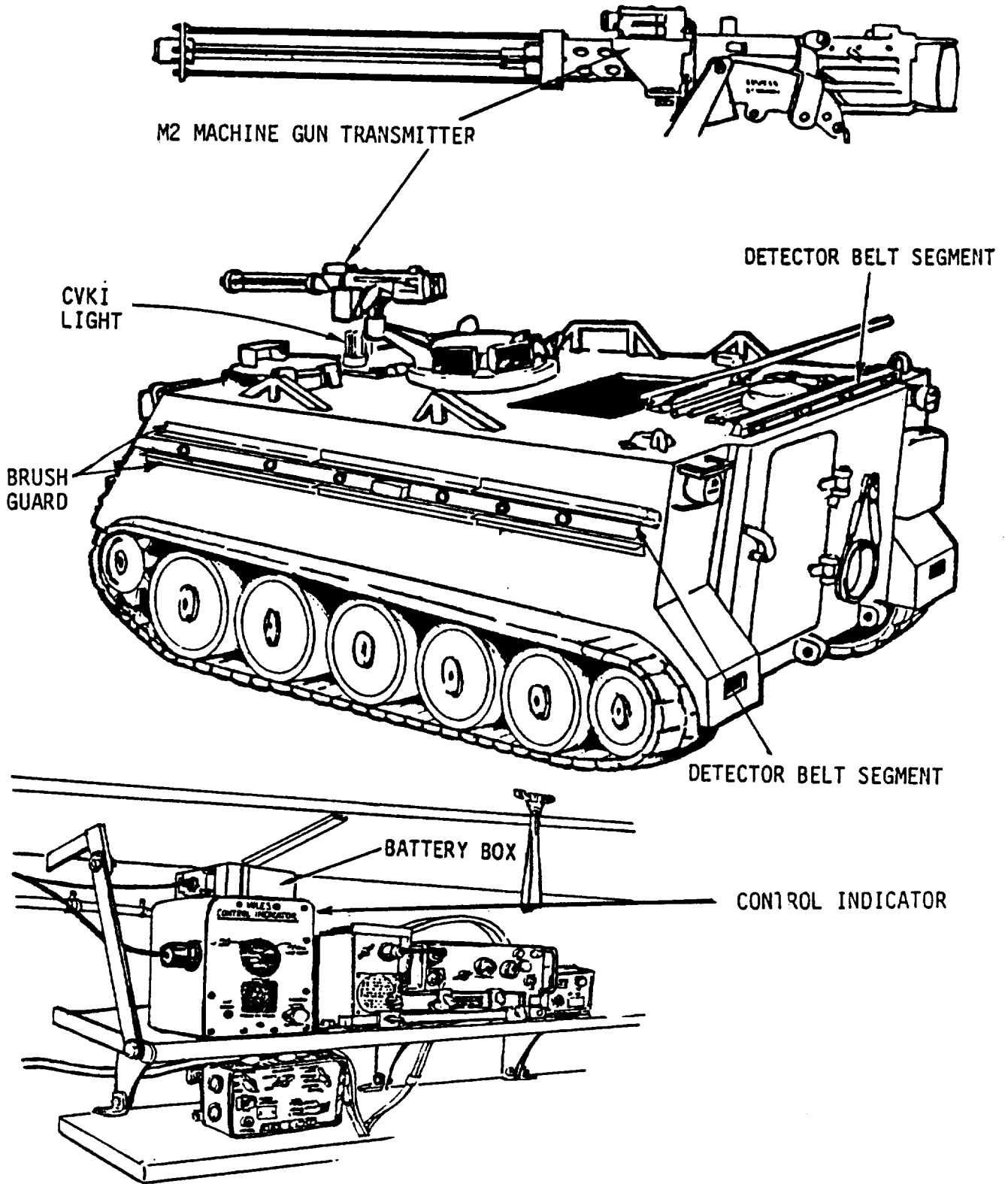

LOCATION OF COMPONENTS: For M220 TOW VEH (For Information on MILES TOW see TM 9-1265-368-10-2)

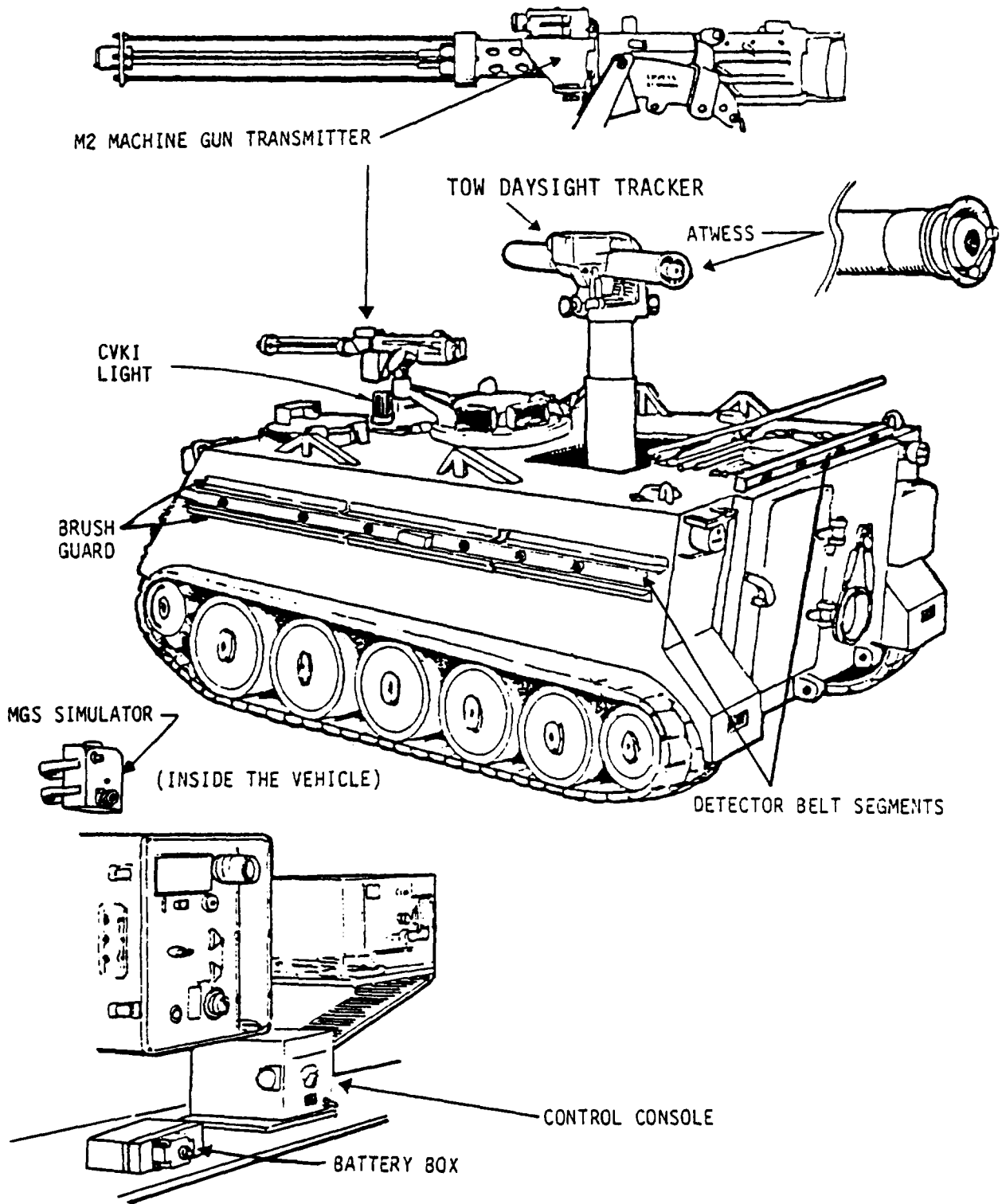

How the MILES Equipment Is Used:

- After the equipment has been installed and tested, you will be ready for the exercise.
- Load the M2 machine gun with blank ammunition. Aim at your target and fire. The sound of blanks firing causes the laser transmitter to fire.
- The laser transmitters on MILES equipment can be fired without using blanks to align the transmitter. To operate transmitters in the "dryfire" mode, a controller key must be used to set the transmitter and dryfire cable must be installed.
- If the laser detector belts on the vehicle are hit by laser fire, one of three things will happen:
 1. The CVKI light will flash two times and two tones will sound in the vehicle's intercom. This indicates a "near miss".
 2. The CVKI light will flash four to six times and four to six tones will sound in the vehicle's intercom. This indicates a "hit" but not a "kill".
 3. The intercom tone will sound and CVKI light will flash continuously. This means a "kill". To turn off tone, you must remove the orange key from the M2 machine gun transmitter, which turns off the transmitter, put the key in the receptacle in the control console, and turn. The CVKI light will continue to flash until reset by a Controller.
- If you attempt to remove the key from the control indicator, the intercom tone will begin again.
- The vehicle driver wears a harness equipped with laser detectors and an alarm. If the harness is "hit" with a MILES-equipped weapon, one of two things will happen:
 1. The alarm on the harness sounds briefly. This means a "near miss". Take cover.
 2. The alarm sounds continuously. This means the driver has been "killed". He must use his yellow weapon key to turn off the alarm.

Equipment Limitations

MILES-equipped weapons have the same range and operational capabilities as the normal weapons, but a dirty laser transmitter lens may reduce the effective range of the transmitter. The M2 machine gun is effective against lightly armored MILES-equipped vehicle and personnel.

Task Assignment

- To speed up installation of the MILES equipment on the M113 APC and M220 TOW vehicle, the inspect and install tasks are divided among the crew members. This way several tasks can be done at the same time.
 - Outside Tasks (1-9) are found on pages 15-27.
 - Inside Tasks (1-5) are found on pages 28-35.
 - M2 MG Tasks (1-4) are found on pages 36-39.
 - MWLD Tasks (1-5) are found on pages 40-44.
- The vehicle commander will assign each crewman to a set of tasks. The crewman turns to the appropriate task section and performs his tasks.
- Occasionally, the manual will tell you to wait to do a task until you have made sure that another crewman has completed an earlier task. On some tasks, two crewmen will work together. Certain tasks must be done with the Controller present. The vehicle commander will determine when to call the Controller.
- The vehicle commander should coordinate the tasks, give assistance to any crewman who needs it, and check to make sure everything gets done.

Install Velcro Tape

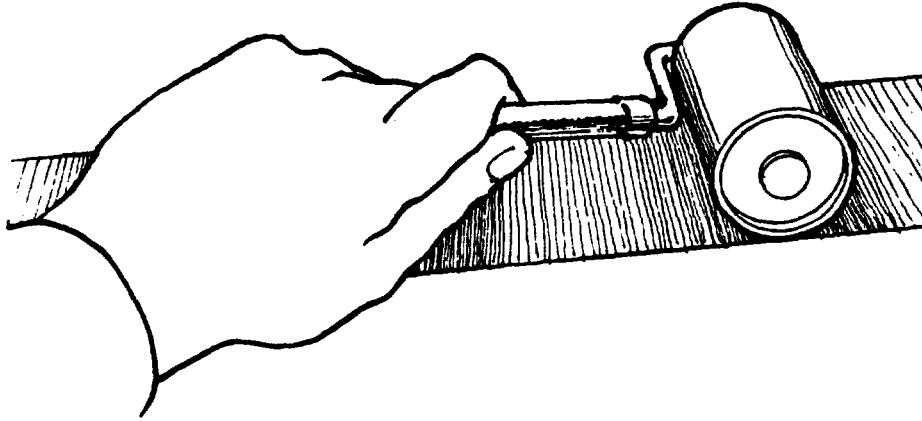

GENERAL INSTRUCTIONS FOR INSTALLING VELCRO TAPE

1. Before starting to mount Velcro Tape, study the steps in this procedure. Before spraying the mounting tape primer, be sure you know where to mount the Velcro. The location of the Velcro is shown in the drawings on the next few pages.
2. Clean all the areas where Velcro is to be mounted with water, brush, and rag. The tape will not stick to dirt and grease.
3. Mark the areas and cut Velcro to appropriate lengths.
4. Spray tape primer on the areas where Velcro will be mounted.
5. Mount the Velcro Tape as instructed in the steps on the following pages.
 - The Velcro tape has a protective paper backing which must be removed before mounting the tape. For small lengths of tape, however, it is recommended that the backing material be removed while the tape is being installed. This will prevent the adhesive on the back of the tape from accidentally sticking to itself.
6. After you put the Velcro in place, press it VERY HARD with the roller. Use the roller as shown in the picture above.

GET A ROLL OF VELCRO TAPE, TAPE PRIMER, AND A ROLLER FROM YOUR NCOIC.

CLEAN THE VEHICLE:

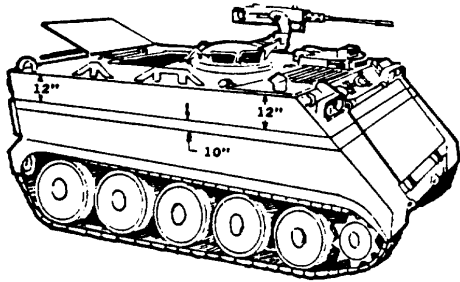

1. With water, clean a strip about 10-inches wide on both sides and the front beginning about 12 inches from the top.
Clean area above door in rear.

MARK LOCATION OF TAPE:

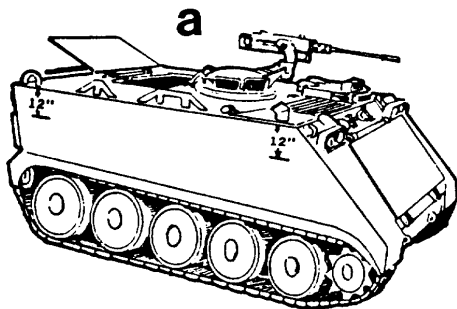

- 2a. On the side shown, make two marks, each 12 inches from the top of the vehicle.

b. You can make the marks on the vehicle with pieces of electrical tape, or cut off thin pieces of Velcro tape and use them.

c. Spray a heavy coat of tape primer on the areas marked. Allow the primer to dry thoroughly.

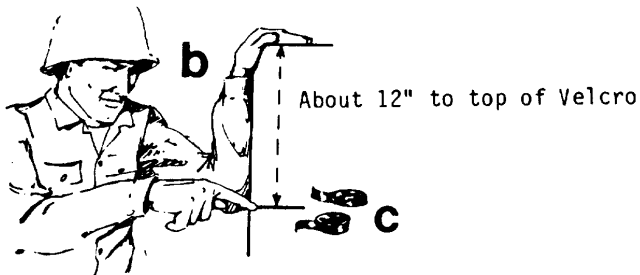

INSTALL VELCRO ON SIDES:

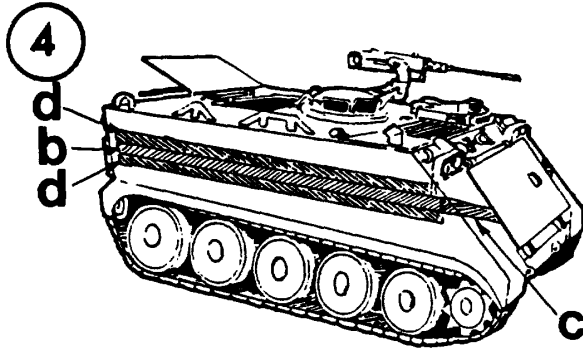
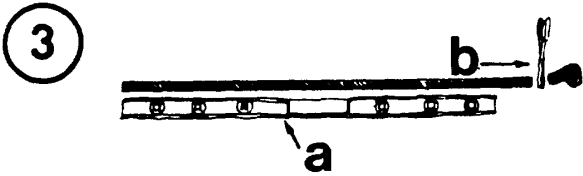

INSTALL VELCRO ON FRONT:

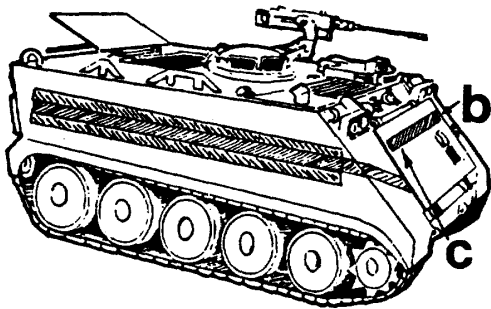

GET ANOTHER SOLDIER TO HELP WITH THE NEXT STEPS.

- 3a. Stretch one of the detector belts labeled No. 1 out on the ground.
- b. Unroll length of Velcro tape 6 inches longer than the belt. Cut the tape.
 - Perform step b. two more times.
 -
 - Be sure that all the places you are putting the Velcro tape have been cleaned and primed.
- 4a. Hold the Velcro tape under the marks you made. Pull the tape straight.
- b. Stick the Velcro tape on the vehicle under your marks. Start 5 inches from the vehicle rear.
- c. Continue the tape around the front and angle it down all the way to the trim vane as shown.
- d. Add two more rows of Velcro; one immediately above and one immediately below the first row. DO NOT continue them around the front. Cut off extra tape. The three rows of tape should be touching each other.
- 5a. Cut Velcro tape about 36 inches longer than a detector belt labeled No. 2.

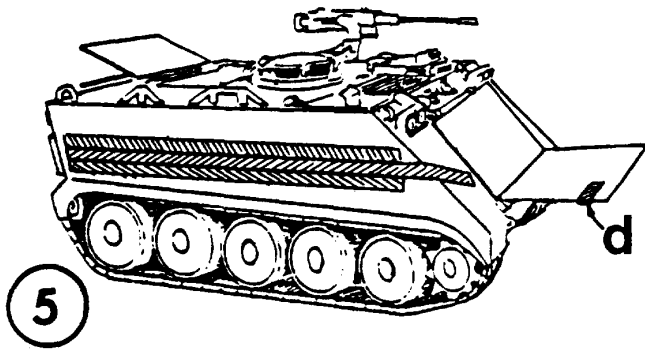

INSTALL VELCRO ON REAR:

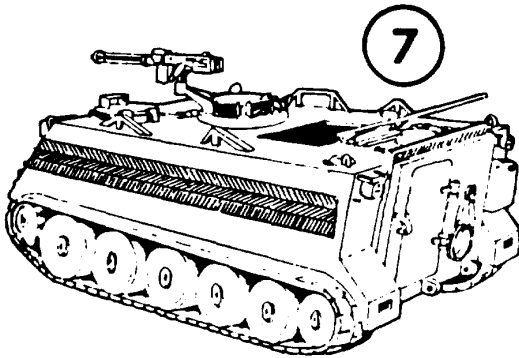
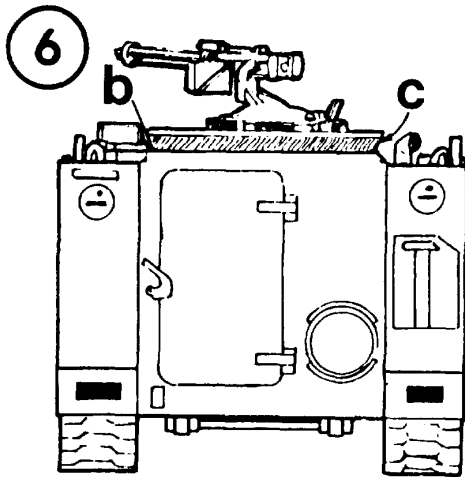
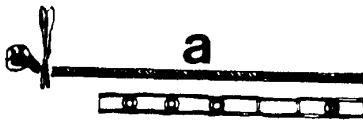

- 5b. Hold the Velcro tape next to the trim vane on the front. Be sure the tape begins about 3 inches from the left side of vane (your right as you face vehicle) and just above trim vane release handle.
 - c. Stick the tape on the trim vane. Make sure area under tape has been first sprayed with tape primer.
 - d. Swing trim vane down and stick remainder of Velcro on the back of vane. Make sure it has first been sprayed with tape primer. Close trim vane. Velcro should wrap around trim vane about half way. If it doesn't, add more Velcro.
- 6a. Cut another piece of Velcro tape about 12" longer than the second detector belt labeled No. 2.
 - b. Beginning on the left rear, stick tape on vehicle body above the swing-down ramp and work toward your right. Make sure it has first been sprayed with tape primer.
 - c. Just past the right side of ramp, make a U-turn with the tape and aim toward the left side of the vehicle.
- 7. Put three pieces of Velcro tape on the last side. Follow steps 3 and 4.

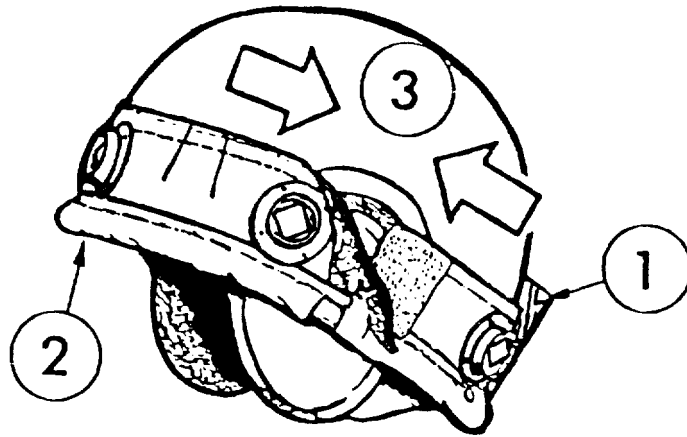

VELCRO MOUNTING INSTRUCTIONS FOR VEHICLE HELMET

The vehicle helmet requires three patches of Velcro glued to the outside to hold the MWLD helmet harness in place. The Velcro patches must be attached to the proper position on the helmet so that they will mate with the three patches of Velcro which are attached to the harness.

1. Slip the helmet harness over the helmet so that the electronics box is at the rear.
2. Make sure the thick bottom edge of the harness completely covers and overhangs the rim of the helmet.
3. Pull the harness tight and mark the helmet where the three to five Velcro patches on the harness touch the helmet. Remove the harness.
4. Spray tape primer over the marked areas where the Velcro will be attached. Allow spray to dry.
5. Cut three to five patches of Velcro (approximately 2 inches long).
6. Remove backing paper and firmly press the patches onto the helmet.

TASK 1: OUTSIDE. Inspect Velcro Tape

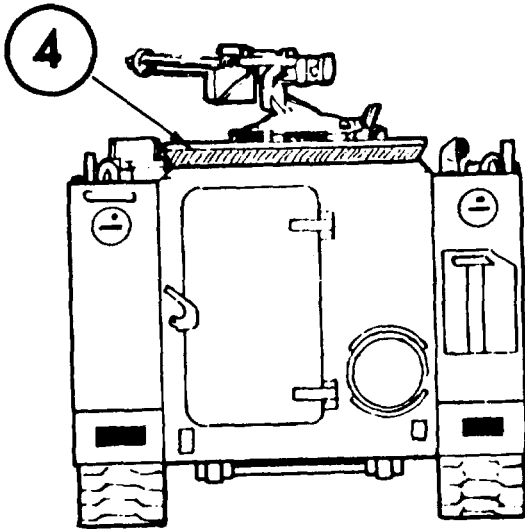
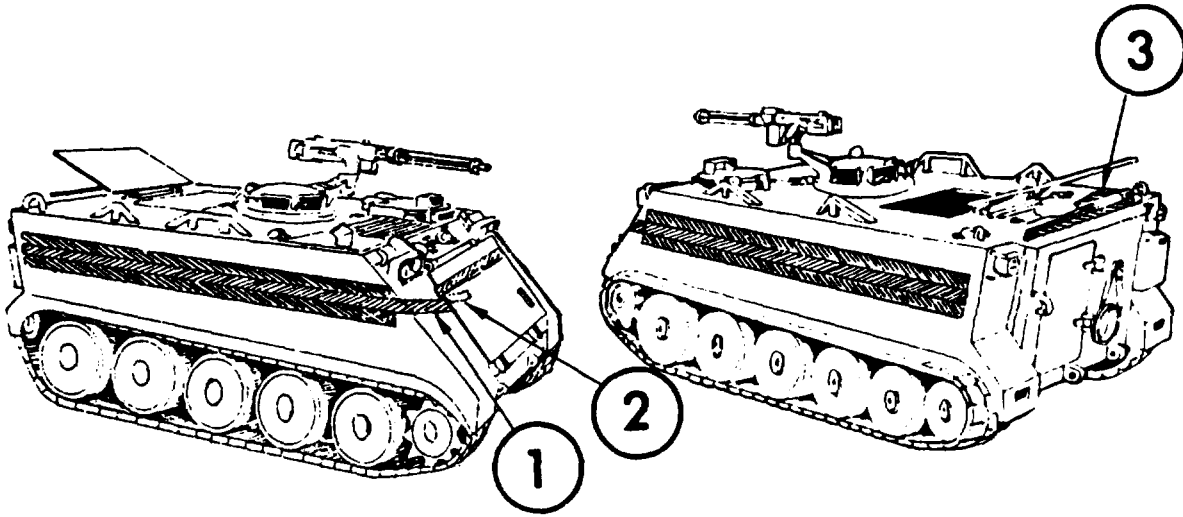

- Be sure velcro tape is in all the places shown. If any tape is missing, use the instructions given on pages 13 through 16 and put on the missing Velcro.

1. There are three rows of Velcro on the vehicle sides, the middle row continues around the front of the vehicle.
2. On the trim vane, the Velcro wraps around the back about halfway.
3. Make sure there is a 12 inch length of Velcro on the top.
4. On the vehicle rear, the Velcro is installed on the door frame above the ramp.

TASK 2: OUTSIDE. Get This Equipment From Your NCOIC

M113 APC EQUIPMENT:



(2) DETECTOR BELT SEGMENTS LABELED NO. 2



(2) DETECTOR BELT SEGMENTS LABELED NO. 1

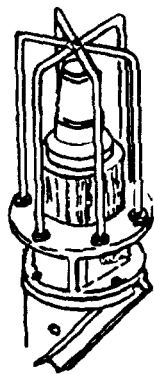

CVKI LIGHT

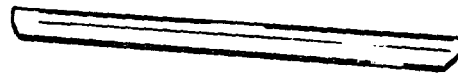

(12) BRUSH GUARDS

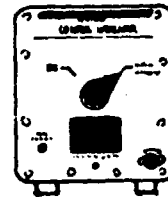

CONTROL INDICATOR

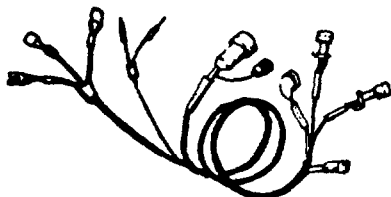

CVKI CABLE ASSEMBLY

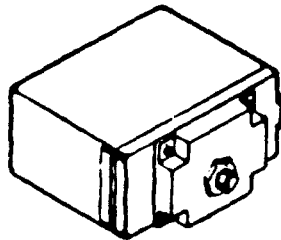

BATTERY BOX



Attaching Bolts



MOUNTING PLATE (M220 TOW ONLY)

TASK 2: OUTSIDE

M2 MACHINE GUN EQUIPMENT:

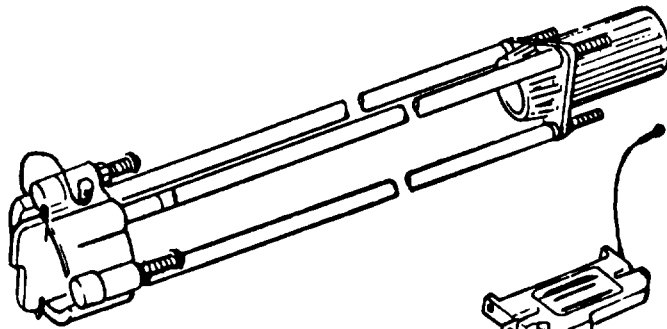

BLANK FIRE ADAPTER

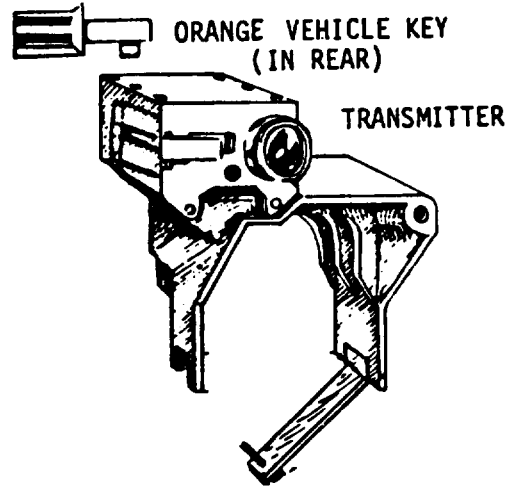

**ORANGE VEHICLE KEY
(IN REAR)**

TRANSMITTER

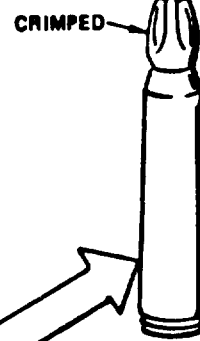

**USE THIS
AMMO ONLY**

CRIMPED

M1E1 BLANK

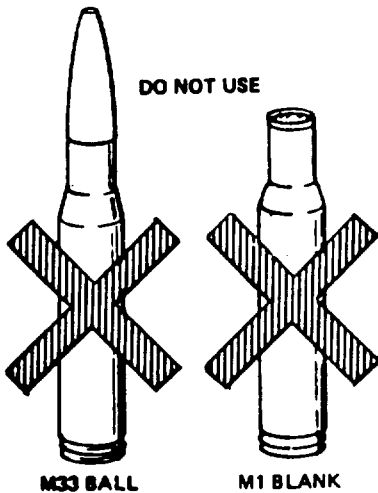

DO NOT USE

M33 BALL

M1 BLANK

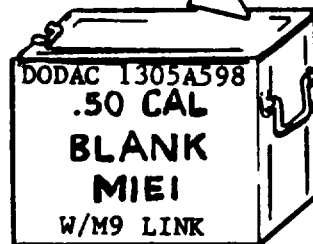

**BLANK AMMUNITION FOR M2
MACHINE GUN**

**M220 TOW VEHICLE
EQUIPMENT ALSO INCLUDES:**

Simulator System, Firing
Laser: M64 for TOW
Weapon System

TASK 2: OUTSIDE

BATTERIES:

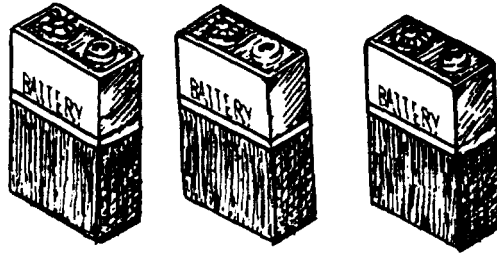

3 9-VOLT BATTERIES
BA-3090/U FOR THE M2
TRANSMITTER AND MWLD HARNESS

2 6-VOLT BATTERIES
BA-200/U
FOR BATTERY BOX

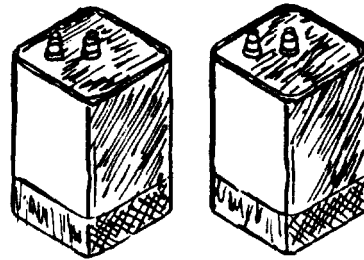

TASK 2: OUTSIDE

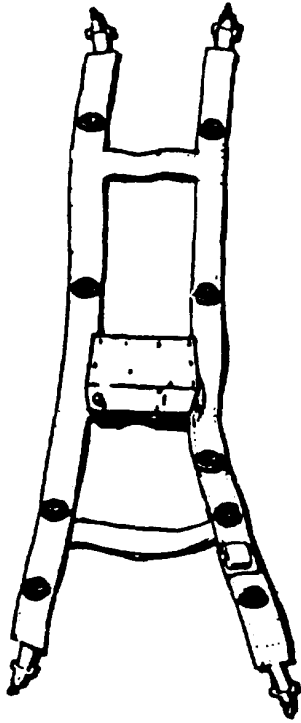

MILES MAN WORN LASER DETECTOR EQUIPMENT (MWLD):

- The MWLD equipment is worn by the vehicle driver.

MWLD TORSO HARNESS

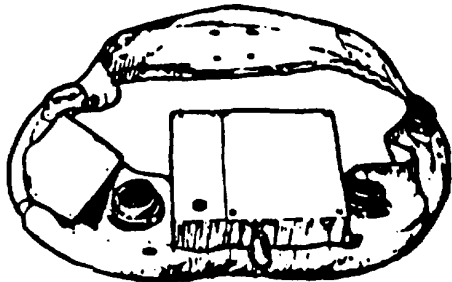

MWLD HELMET HARNESS YELLOW KEY

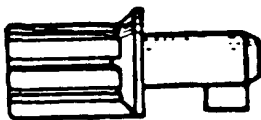

- The vehicle driver carries this key.

TASK 3: OUTSIDE. Inspect & Service Detector Belt Segments & Brush Guards

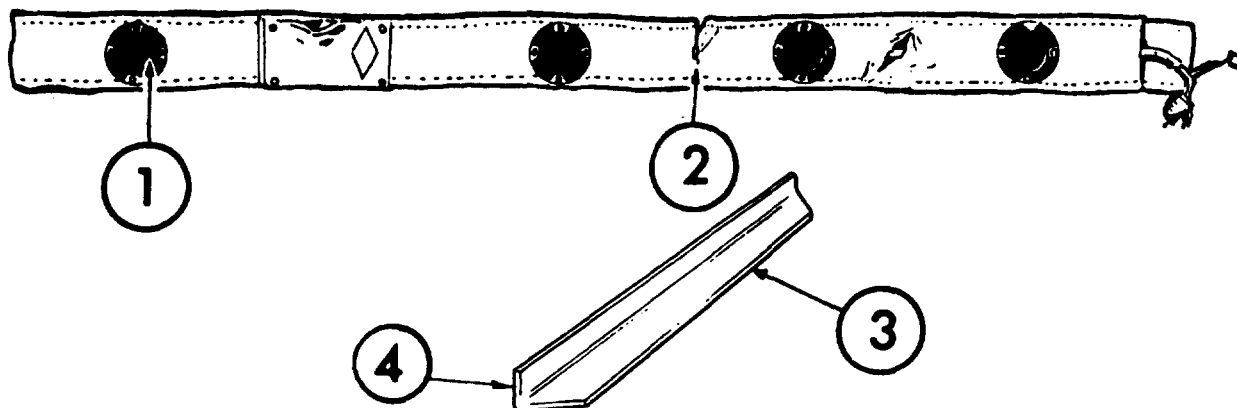

CHECK ALL FOUR BELT SEGMENTS:

1. Wipe all detectors clean.
2. Inspect belt segments for damage that would prevent normal operation.

CHECK ALL TWELVE BRUSH GUARDS:

3. Inspect twelve brush guards for bends that would prevent them from being securely fastened to the vehicle.
 4. Make sure Velcro is securely mounted on the rear of the brush guards. If Velcro is missing, report on DA Form 2402 and replace brush guard.
- Report any damage on DA Form 2402 and replace belt segments or brush guards if unusable.

TASK 4: OUTSIDE. Install Detector Belt Segments

CAUTION

Do not spill fuel on detector belts or Velcro. Fuel dissolves the adhesive properties of the tape primer and may cause a detector belt to fall from the APC, causing damage or loss of a detector belt.

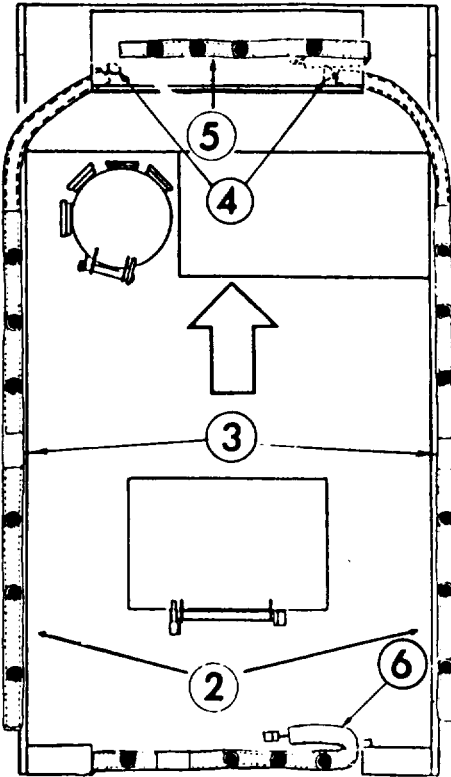

1. Find the label on each detector belt segment. Belt segments labeled No. 1 go on the vehicle sides. Segments labeled No. 2 go on the front and rear.
2. Put the No. 1 belt segments on the vehicle sides. There are three rows of Velcro tape on the vehicle sides. Use the center row. Be sure the connectors are at the vehicle's front.
3. Begin by placing the connector behind the trim vane and work toward the rear.
4. When properly installed, the connectors will be hidden behind the trim vane. If connectors are not behind trim vane, move the belt segment forward. Repeat Steps 3 and 4 for the other side.
5. Put a No. 2 belt segment on the vehicle front. Be sure the connector is on your left. Wrap the belt segment around the right side (side opposite driver) of the trim vane so that the electronics box and connector are hidden behind the vane. If the vehicle does not have a trim vane, center the cable segment across the front of vehicle.
6. Put a No. 2 belt segment on the vehicle rear with the connector as shown.

CAUTION

Ensure that the bottom edge of the belt does not fall below the bottom edge of the ramp door frame.

TASK 5: OUTSIDE. Install Brush Guards

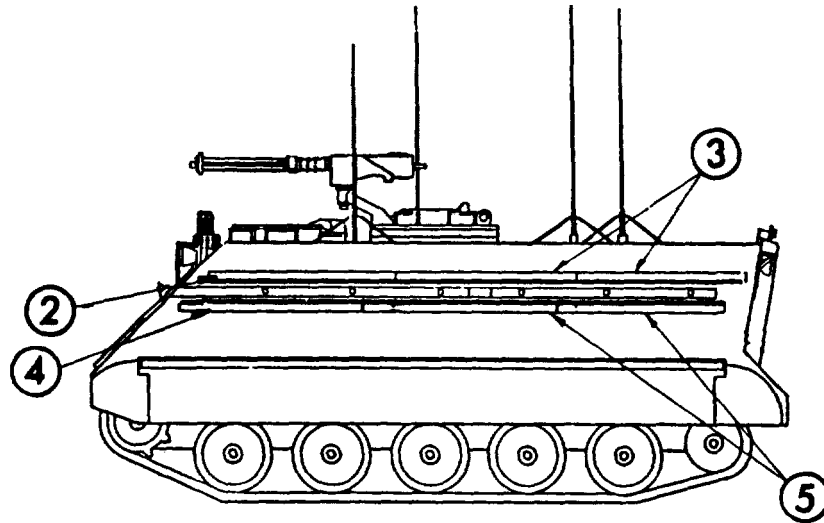

CAUTION

Do not spill fuel on brush guards or Velcro. Fuel dissolves the adhesive properties of the tape primer and may cause a brush guard to fall from the APC, causing damage or loss of a brush guard.

1. Install three brush guards above and three brush guards below the detector belt on each side of the vehicle on the other two rows of Velcro tape. No brush guards are installed on the front or rear.
 2. Begin at the front of the vehicle. Install the first guard on the top row of Velcro. Make sure the edge of the brush guard does not stick out in front of the vehicle. Place the brush guards so that the short unvelcroed side of the guard is closest to the belt.
 3. Install two more brush guards on the top row of Velcro.
 4. Beginning at the front of the vehicle again, install another brush guard on the bottom row of Velcro. Make sure the edge of the brush guard does not stick out in front of the vehicle.
 5. Install two more brush guards on the bottom row of Velcro.
- Repeat steps 2 through 5 for the other side.

TASK 6: OUTSIDE. Inspect CVKI

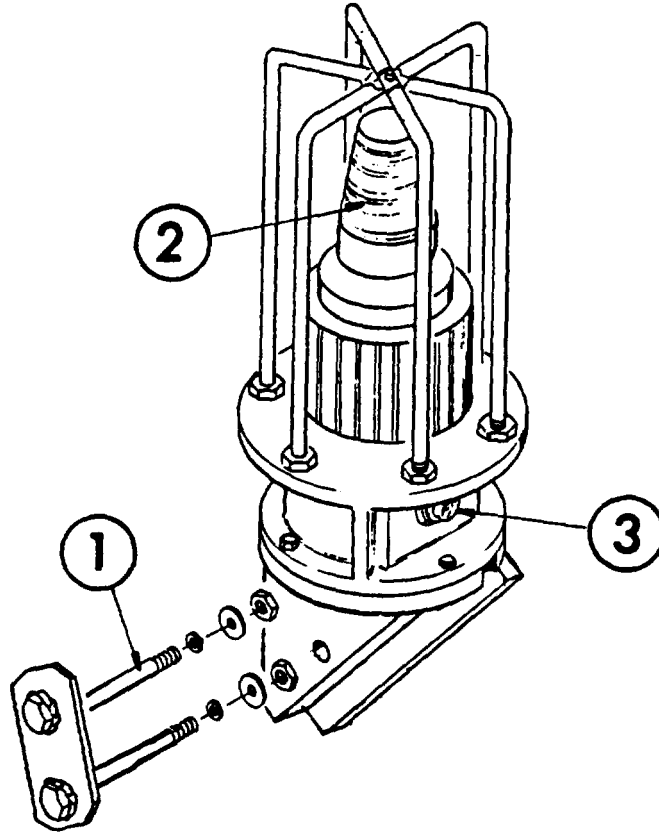

1. Make sure nuts on mounting attachment bolts turn freely and threads on bolts are not stripped.
 2. Inspect yellow plastic lens for cracks.
 3. Inspect receptacle and pins for damage.
- Report any damage on DA Form 2402, and replace if unusable.

TASK 7: OUTSIDE. Install CVKI

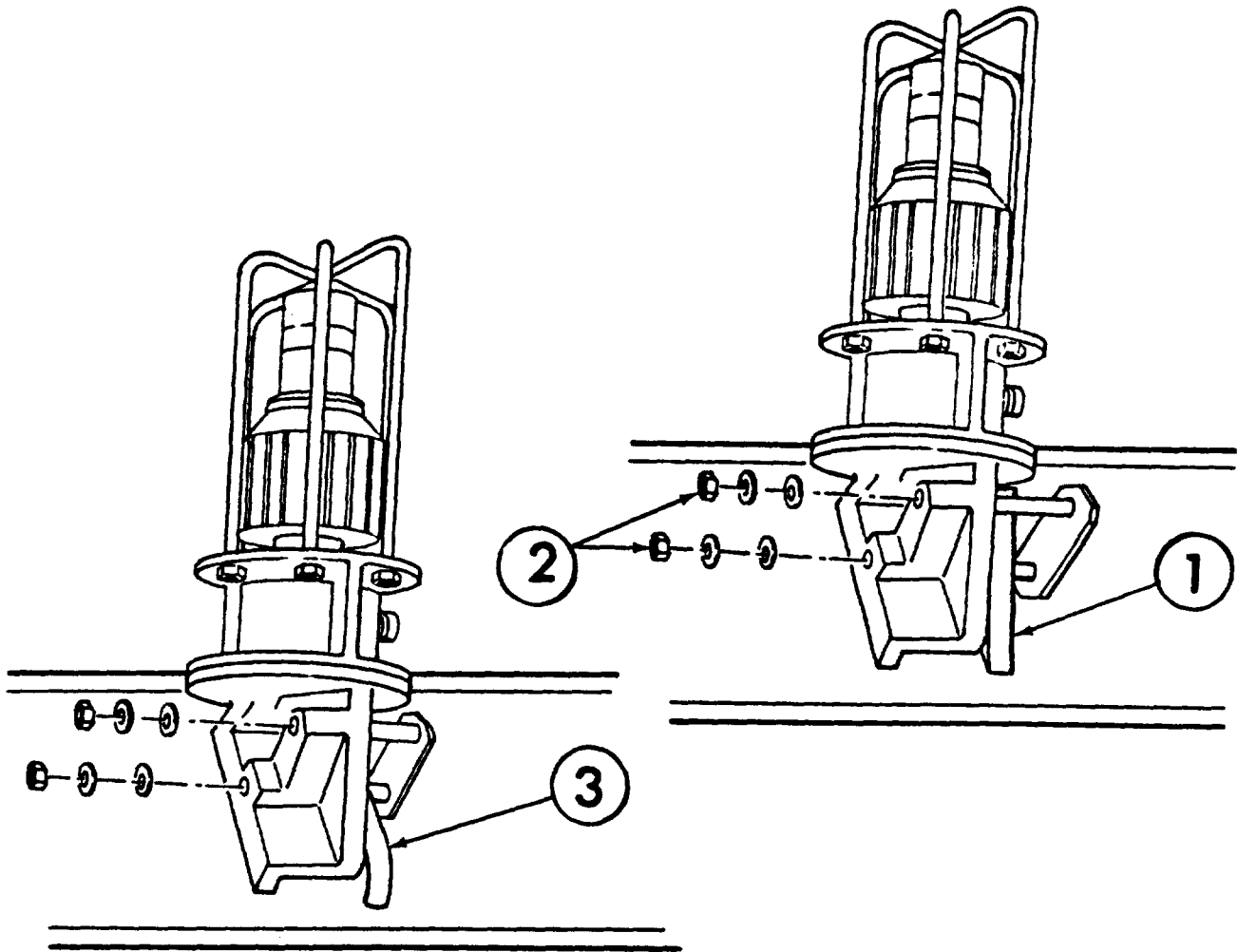

1. Mount CVKI light to the engine cover lifting eye using mounting holes in the adapter as shown. Make sure mounting bracket is flush against eye and vehicle body.
2. Tighten mounting bolts.
3. If your vehicle doesn't have an engine cover lifting eye, then mount assembly to nearby utility bracket with the CVKI connector facing inboard as shown.

NOTE

If it is not possible to mount the assembly with the CVKI connector facing inboard, you have a CVKI Adapter that needs an additional pin hole drilled. Notify your NCOIC before proceeding further with the installation.

TASK 8: OUTSIDE. Inspect CVKI Cable Assembly

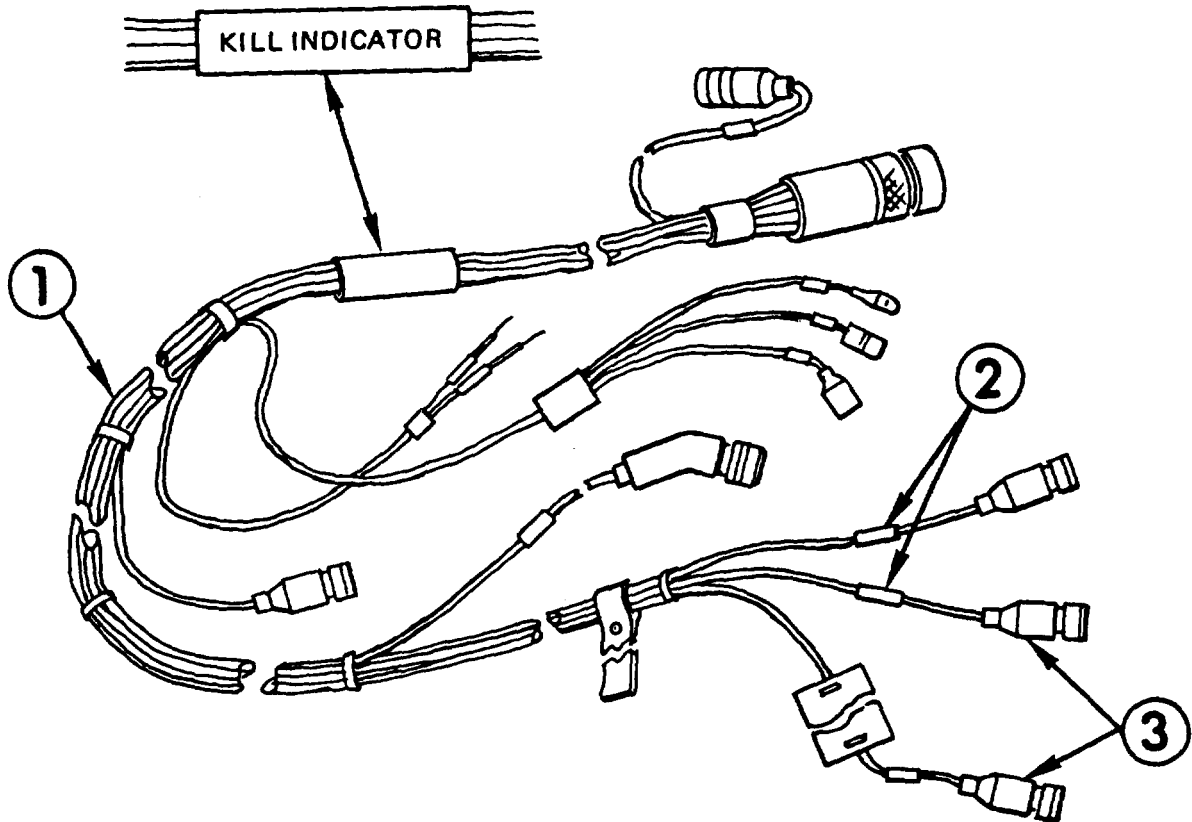

1. Check the cable assembly for worn insulation or bare wires.
 2. Each connector should have a label that shows where it goes.
 3. Check all connectors for obvious damage.
- Report any damage on DA Form 2402, and replace CVKI cable assembly.

TASK 9: OUTSIDE. Install CVKI Cable Assembly

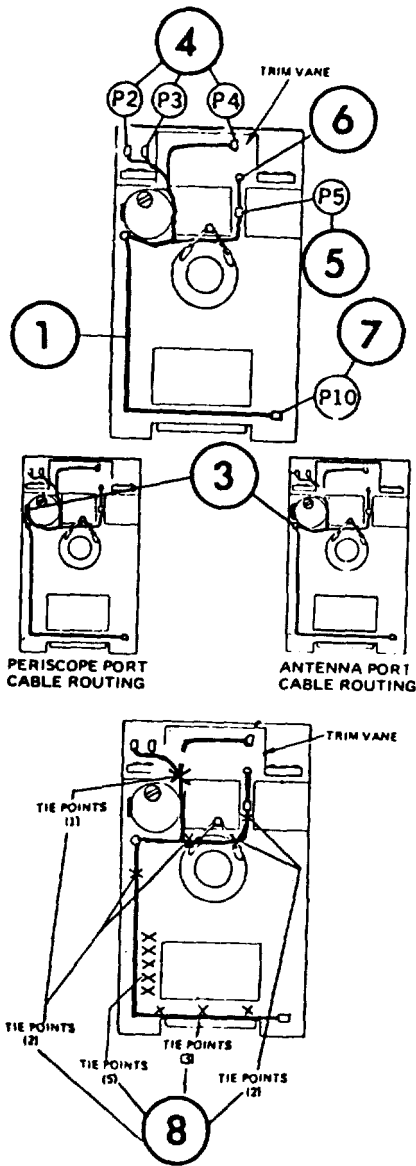

1. Climb on top of the vehicle and lay out the cable assembly as shown.
2. Find the cable ends labeled P2, P3, P4, P5, and P10. Pull them away from the other cables.
3. Feed the inside cable connector ends into the vehicle through either the forward antenna port or driver's left periscope port.
4. Route cables P2, P3, and P4 between driver's hatch and air intake grill and drop the cables down the front of vehicle.
5. Route cable labeled P5 in front of machine gun turret and between air intake and exhaust grills to the back of the CVKI.
6. Attach P5 to the CVKI receptacle.
7. Route cable labeled P10 to the left rear of the vehicle and connect to the rear detector belt segment. Put the connector under the Velcro flap on the belt.
8. Securely attach cable to the 13 tie points shown using the Velcro tie straps. Climb down from vehicle.

NOTE

Two people are required to perform the remaining steps.

TASK 9: OUTSIDE

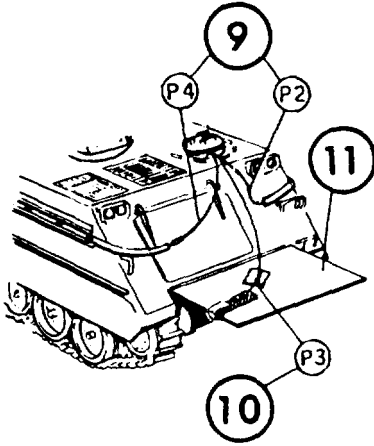

9. Release trim vane and swing down. Plug the cable labeled P2 into the left (driver's side) detector belt segment and the cable labeled P4 into the right side detector belt segment. Make sure the connectors and all excess cable are located in areas that will be covered by the trim vane when closed. Put the connector under the Velcro flap on the belt.
10. Raise the trim vane until it is approximately horizontal. Plug the cable labeled P3 into the connector on the front belt segment. Again, make sure that the connector and all excess cable are located in the area that will be covered by the trim vane when it is closed. Put the connector under the Velcro flap on the belt.
11. Close and secure the trim vane making sure that all connectors and excess cable are protected by the trim vane.
12. If the vehicle does not have a trim vane installed, gather up the excess cable labeled P4 and route it along the top of hinge to the engine access door.
13. Secure the cable to the hinge with the two Velcro tie straps attached to the cable.

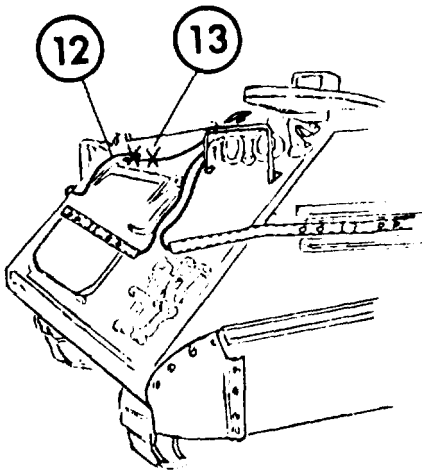

TASK 1: INSIDE. Inspect Control Indicator

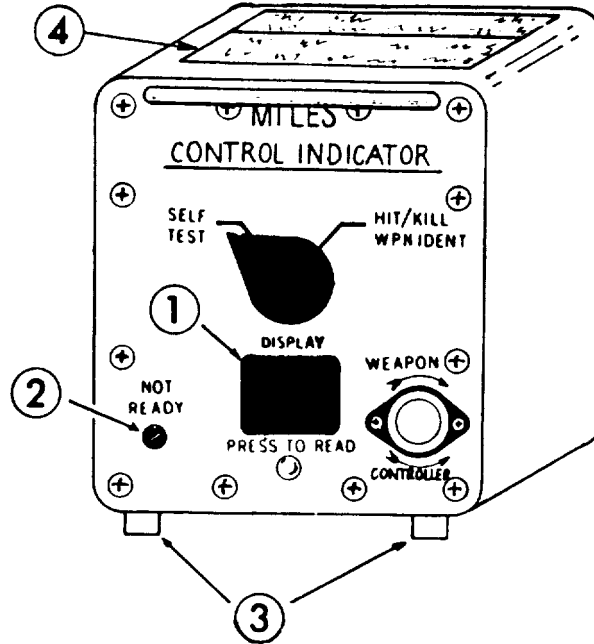

- Before doing this task, check with the vehicle commander to make sure Outside Task 1 has already been done.
- 1. Look for cracks in the display.
- 2. Make sure the lens on the NOT READY LIGHT is not broken.
- 3. Check that both mounting bars are attached to the bottom of the control indicator.
- 4. Make sure Velcro tape is securely fastened to top of indicator.
- If tape is loose or missing, read the general instructions for installing Velcro tape on page 12 and replace the tape. Attach two strips of Velcro side-by-side as shown.
- Report any damage on DA Form 2402, and replace control indicator.

TASK 1: OUTSIDE. Install Control Indicator

M113 APC Installation

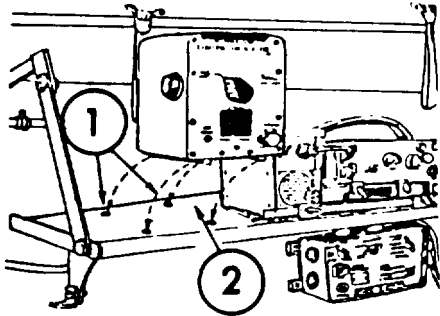

See next page for instructions on installing control indicator on M220 TOW vehicle.

1. Check the shelf to be sure four holes have been drilled for installation of the control indicator.
2. Put the control indicator on the shelf over the four holes.
3. Bolt the control indicator to the shelf with the four bolts provided. Tighten bolts.

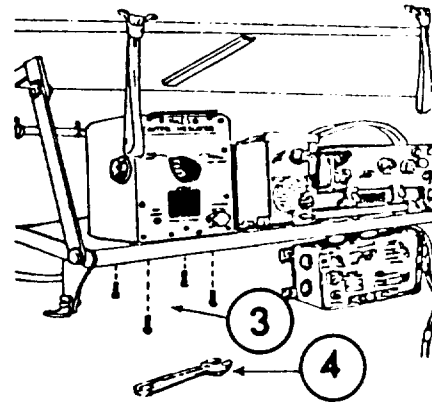

TASK 2: INSIDE

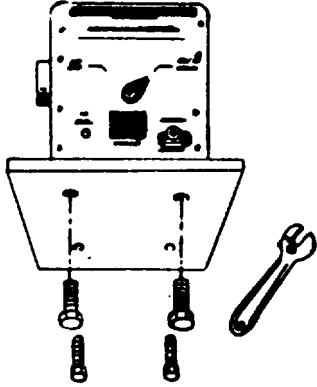

M220 TOW Vehicle Installation

See preceding page for instructions on installing control indicator in M113 APC.

1. Turn control indicator upside down. Bolt retainer plate to the bottom of the control indicator. Use the four bolts provided.
2. Put control indicator and retainer plate on shelf beneath TOW missile guidance system. Position retainer plate over four holes in shelf.
3. Attach retainer plate to shelf with four bolts provided. Tighten bolts.

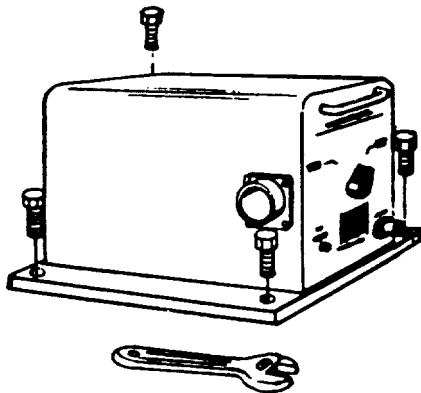
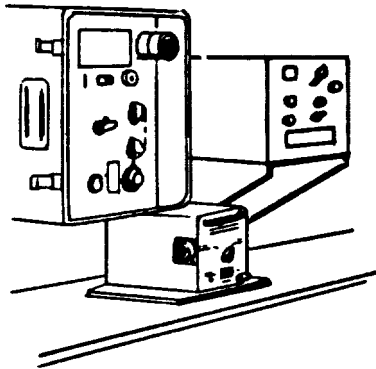

TASK 3: INSIDE. Inspect Battery Box

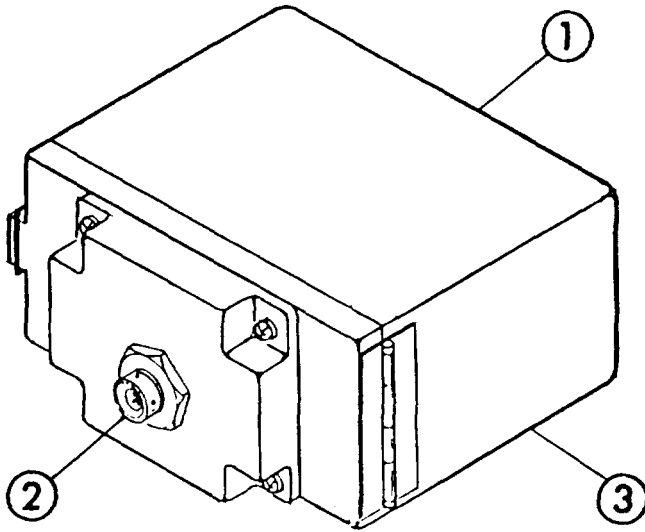

1. Inspect case for any damage that would prevent batteries from being inserted and the cover from properly closing.
2. Inspect connector for bent or damaged pins.
3. Inspect Velcro on bottom of case for any damage that would prevent it from properly holding the battery box. If Velcro is missing, do not attempt to replace it. Report on DA Form 2402, and replace battery box.

TASK 4: INSIDE. Install Battery Box and Batteries

M113 APC Installation

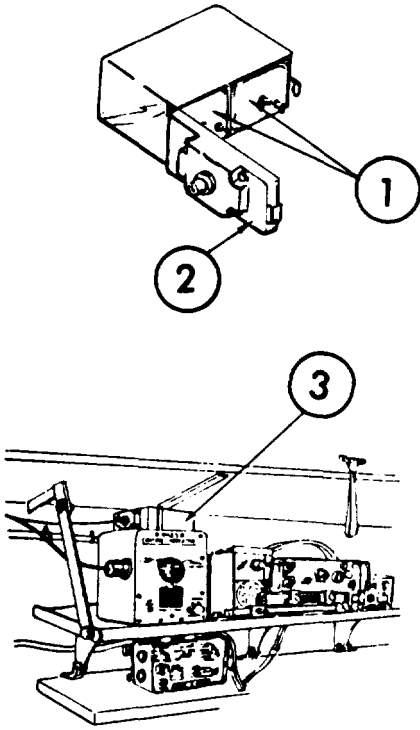

See next page for instructions on installing battery box in M220 TOW vehicle.

1. Unlatch and open cover of battery box.
2. Install two 6-volt batteries in the battery box.
3. Close and latch cover of battery box.

NOTE

If the battery box cannot be installed in the location shown, relocate to another nearby position. Do not mount battery box in a vertical position. It will be necessary to mount two pieces of Velcro in the new position. See step 3 on the next page for Velcro installation instructions.

4. Install battery box on top of the control indicator, using Velcro tape on top of control indicator and bottom of battery box.

TASK 4: INSIDE

M220 TOW Vehicle Installation

See the preceding page for instructions on installation of the battery box in the M113 APC.

1. Unlatch and open cover of battery box. Insert two 6-volt batteries in box.
2. Close and latch cover of battery box.

NOTE

If the battery box cannot be installed in the position shown, relocate it to a nearby convenient position. Do not mount battery box in a vertical position.

3. Cut two 6-inch strips of Velcro and glue them, side-by-side, at the location where the battery box will be mounted. Refer to the general instructions on page 12 for installing Velcro.
4. Install battery box on the Velcro as shown.

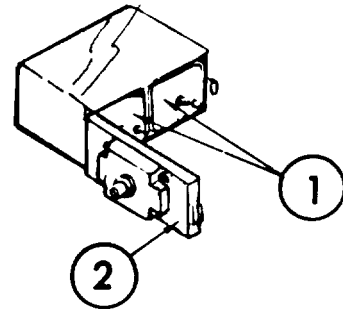

2

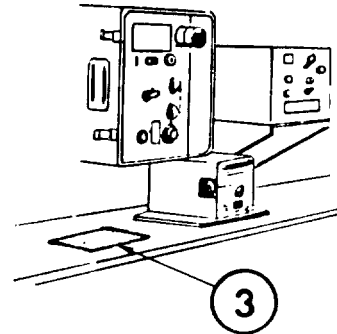

3

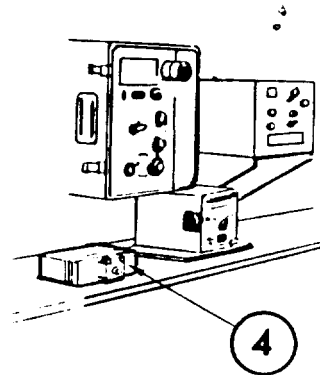

4

TASK 5: INSIDE. Finish Installing Cable Assembly

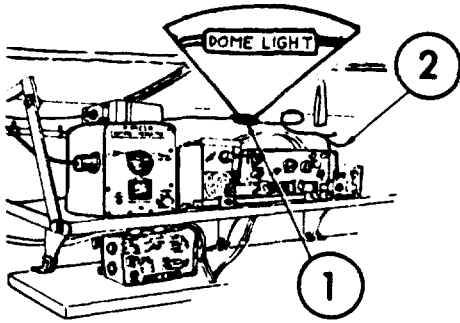

- First, check that Outside Task 9 has already been done. Ask your commander.

- Find the cables routed in the periscope port from the CVKI and detector belt segments.

1. Locate connectors labeled DOME LIGHT.
2. Guide the dome light cable toward the driver's dome light.

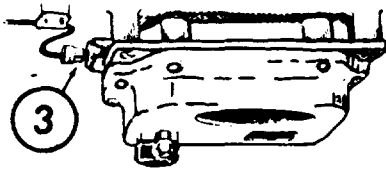

3. Pull the plug out of the driver's dome light.

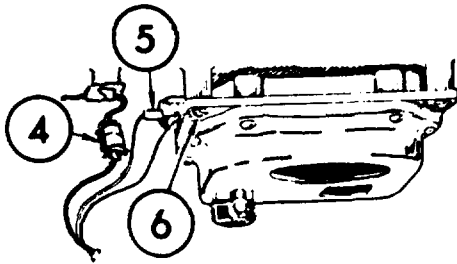

4. Put the plug from the dome light into the MILES connector (P7).

5. Plug MILES connector P6 into the dome light.

6. Remove the closest dome light bolt. Slip the bolt through MILES connector E1. Make sure the connector is touching bare metal. Tighten the bolt.

TASK 5: INSIDE.

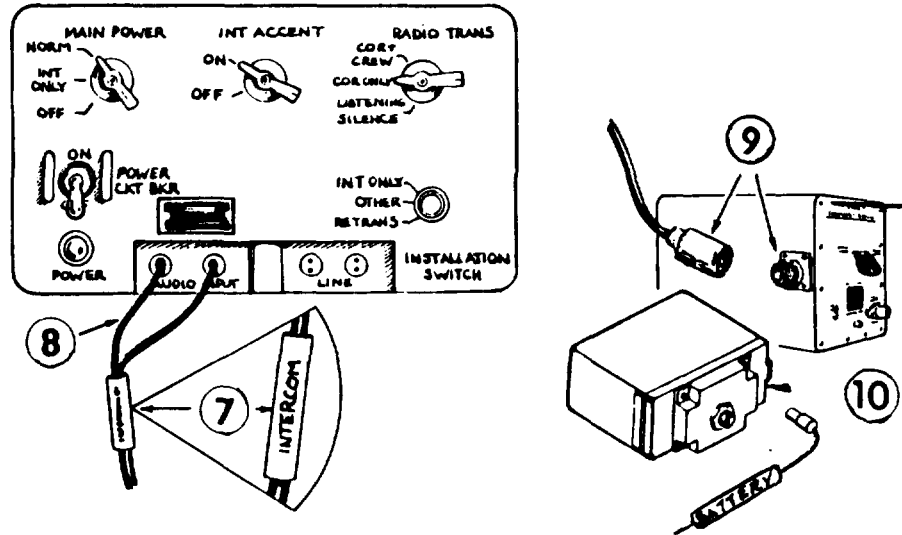

7. Find the MILES cable labeled INTERCOM.
8. Plug MILES connectors P8 and P9 into the AUDIO INPUT jacks on the 1780 intercom unit. Either plug can go in either jack.
9. Find the cable connector labeled CONTROL INDICATOR. Plug it into the jack on the side of the control indicator.
10. Plug cable connector labeled BATTERY into the jack on the front of the battery box.

TASK 1: MG. Inspect and Service M2 Machine Gun Transmitter

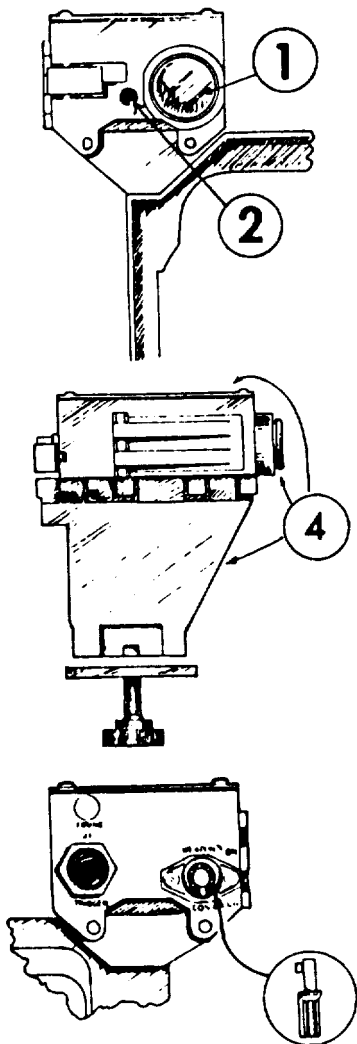

- Before doing this Task, check with the commander to make sure Outside Task I has already been done.
1. Remove any dirt or oil from lens with lens paper or a soft, dry cloth.
 2. Make sure foam microphone cover is dry and not caked with water, dirt, or blank-fire residue.
 - If wet or dirty, call the Controller. He will clean or, if necessary, replace the foam cover.
 3. Check for damage that would prevent normal operation of the transmitter.
 4. Wipe all surfaces clean.
- Report damage on DA Form 2402 and replace transmitter, if possible.

TASK 2 MG. Put Battery in Transmitter

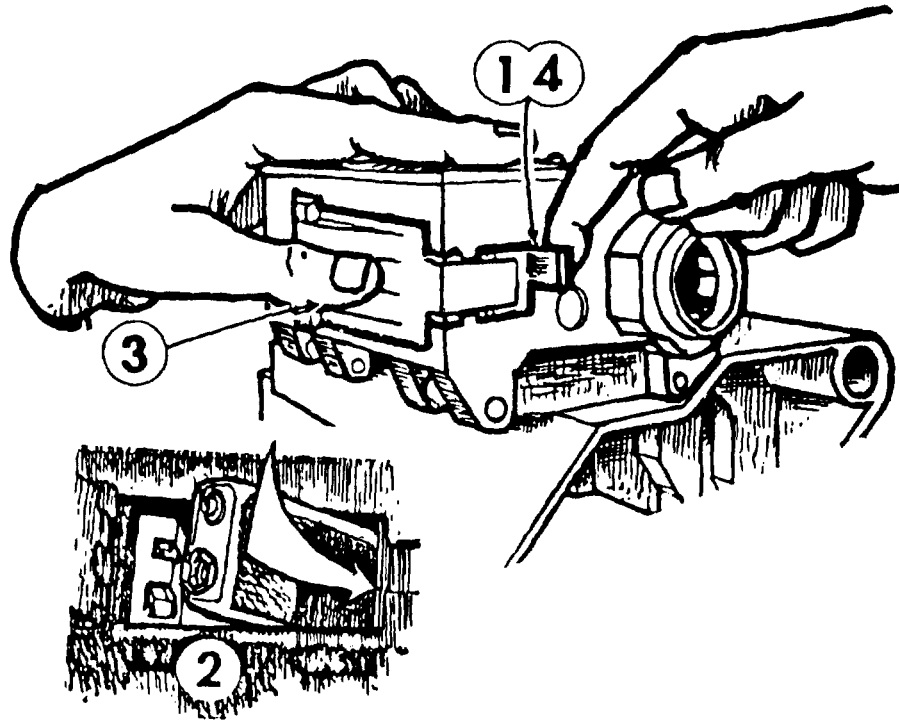

1. Flip open the latch.
2. Open the battery door and put in a battery as shown.
3. Press the door closed and hold it closed with one hand.
4. Press the latch closed with the other hand.

TASK 3 MG. Attach Transmitter

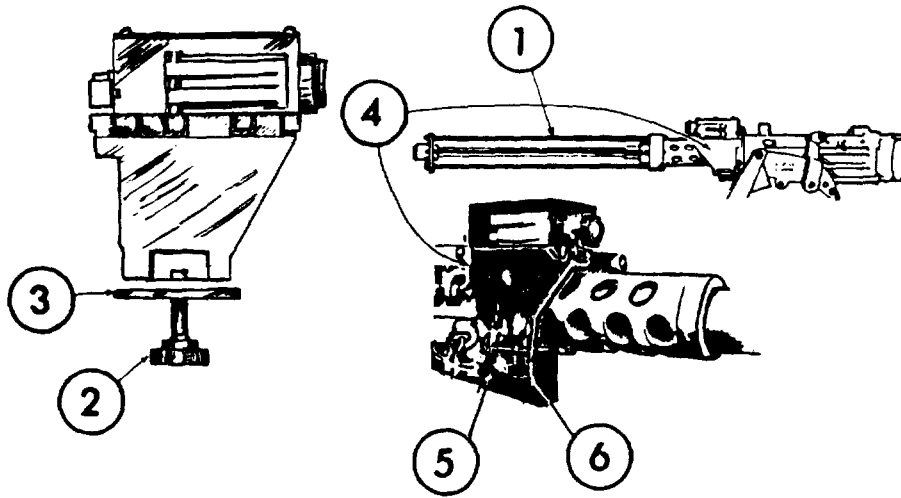

NOTE

Before mounting transmitter, mount M2 machine gun on vehicle and set headspace and timing.

1. Mount blank fire attachment.
2. Unscrew knob from side of bracket.
3. Swing bottom plate down.
4. Mount transmitter on barrel support jacket flush with the front end of the receiver. Be sure the lip of the back of mounting bracket sits behind the barrel cooling jacket so that transmitter is held securely in place.
5. Swing bottom plate back up against transmitter mounting bracket.
6. Tighten knob securely with your hand. As the knob threads start to engage, apply a slight up pressure on the transmitter so that it lines up straight with the barrel.

TASK 4 MG. Blank-Fire Operation

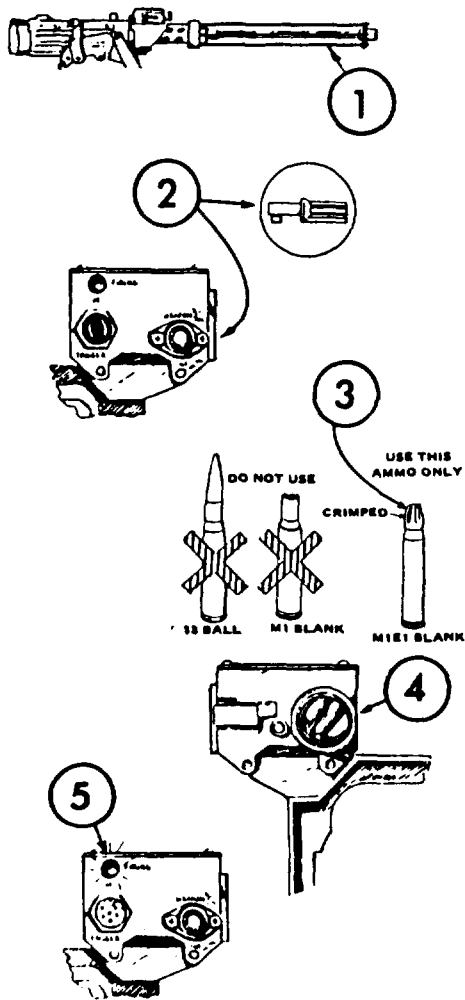

1. Make sure blank fire attachment is installed.
2. Be sure orange key is turned to WEAPON ON or transmitter will not fire.
3. Load the M2 with blank ammunition.

THE M2 IS READY TO FIRE. FIRING IS DONE NORMALLY. THE SOUND OF BLANKS BEING FIRED WILL TRIGGER THE TRANSMITTER. THE TRANSMITTER WILL WORK ONLY AS LONG AS YOUR SUPPLY OF BLANK AMMUNITION LASTS.

4. At least once a day, use a clean dry cloth to remove blank-fire powder residue from transmitter lens.
5. Fire a short burst and watch the firing lamp. It should light.
 - If no light, replace the battery and test again. If still no light, report on DA Form 2402, and replace the transmitter.
 - If the lamp stops lighting while you are using the M2 in the exercise, replace the battery in the transmitter.

TASK 1 MWLD. Inspect and Clean Torso Harness

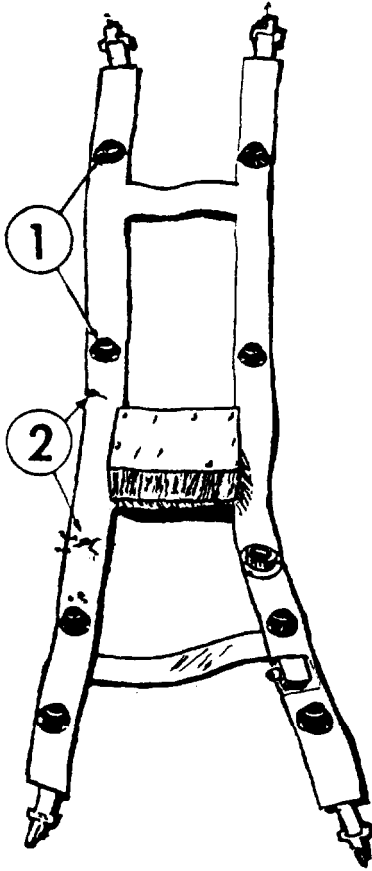

1. Wipe all eight detectors clean.
 2. Inspect harness for damage which would prevent normal operation.
- Report any damage on DA Form 2402, and replace torso harness.

TASK 2 MWLD. Inspect and Clean Helmet Harness

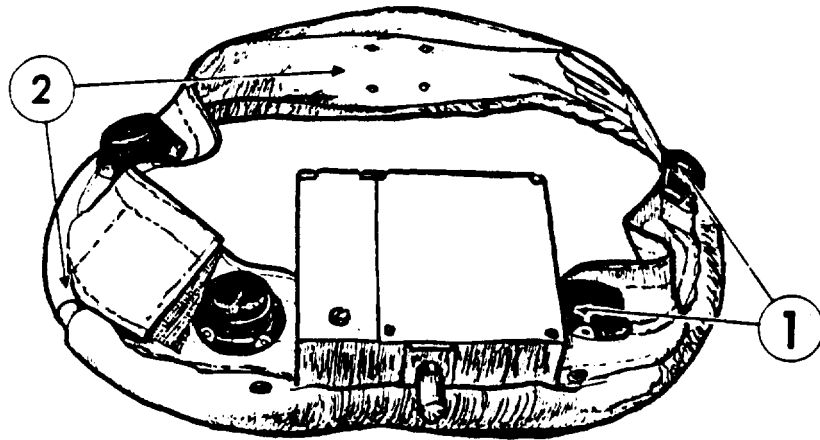

1. Wipe all five detectors clean.
2. Inspect helmet harness for any damage that would prevent normal operation.
 - Report any damage on DA Form 2402, and replace helmet harness.

TASK 3 MWLD. Install Batteries in MWLD Harnesses

Ask your NCOIC to call the Controller.

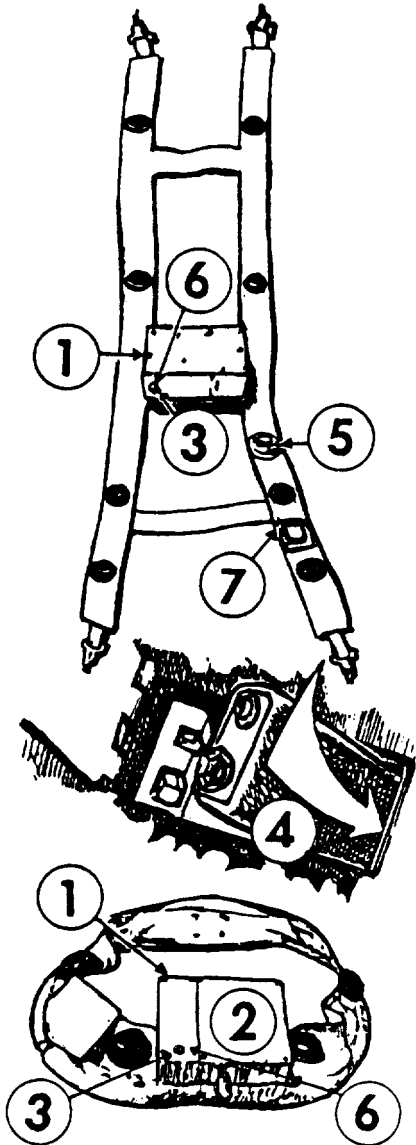

1. Locate battery boxes on both MWLD helmet and torso harnesses.
2. First, put a battery in the helmet harness.
3. Loosen thumbscrew and open door.
4. Insert battery as shown. Push battery down to make sure it fits correctly.
5. Close door and tighten thumbscrew.
6. Put battery in torso harness, repeating steps 3, 4, and 5. When you insert a battery in the torso harness, an alarm should sound. If no alarm, remove and reinsert the same battery. If still no alarm, get a new battery from your NCOIC and try again. If still no alarm, report on DA Form 2402, and replace torso harness.
7. Ask Controller to insert his green key in key receptacle and turn off alarm.

NOTE

Be sure to insert batteries in both the helmet and torso harnesses.

TASK 4 MWLD. Put on Torso Harness

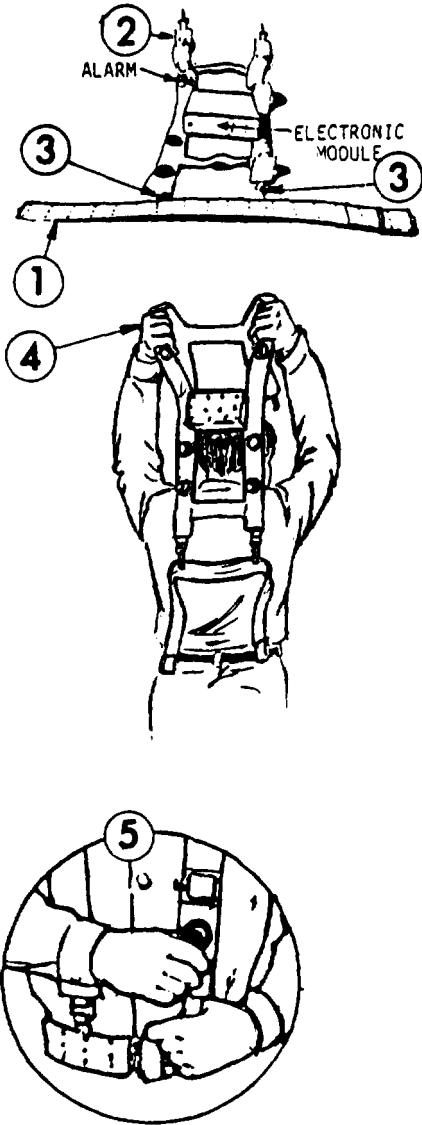

- If you are wearing them, remove the suspenders from your web gear.
1. Remove your web belt and lay it next to the harness like this.
 2. The harness should look like this with the alarm and snaps above the electronics unit.
 3. Fasten both clips to the belt as shown.
 4. With your web belt at the bottom, raise the harness and then lower it over your head.
 5. Fasten your web belt and connect the harness to the belt. Adjust harness so battery box is at the back of your collar, at the collar line.

TASK 5 MWLD. Put Helmet Harness On Helmet

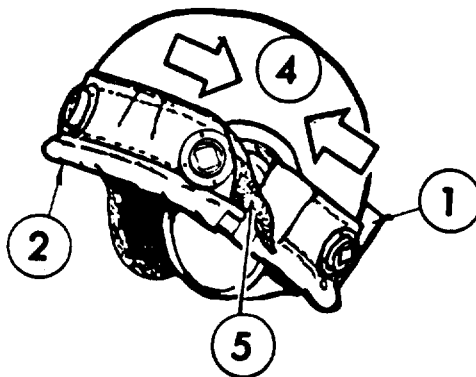

- Your helmet must have three to five patches of Velcro installed on the outside. If you do not have any Velcro on your helmet, turn to page 10 for instructions on installing the Velcro.
1. Slip harness over helmet so that the electronics box is at the rear.
 2. Make sure the heavy cable overhangs the lip of the helmet.
 3. Adjust the harness so that the three to five pieces of Velcro on the inside of the harness line up with the Velcro pieces attached to the outside of your helmet.
 4. Pull the harness ends in the direction of the arrows to tighten the harness.
 5. Fasten the Velcro flap tightly.
- When you wear your helmet, fasten the chinstrap. The added weight of the harness makes this necessary.

TASK 1 TEST. Test Operation of MWLD

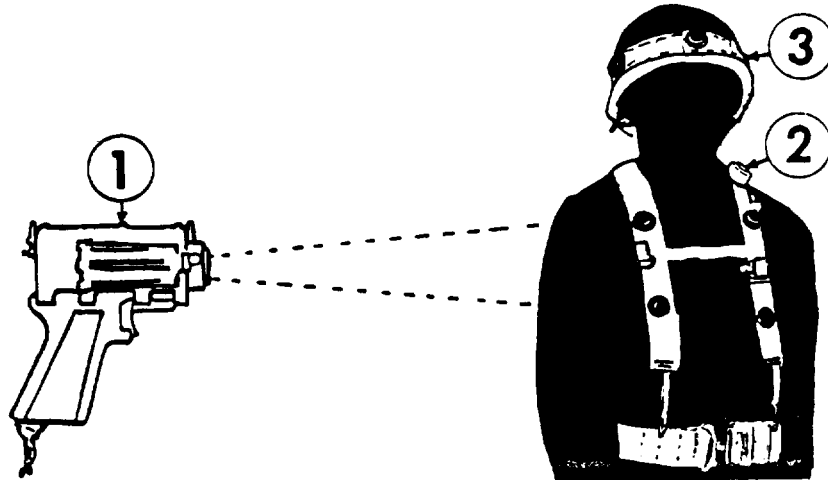

1. Ask Controller to test your torso harness by firing a "near miss".
2. When he fires, your alarm should sound briefly.

NOTE

If no alarm, remove and reinsert the same battery in the torso harness and test again. If still no alarm, replace the battery in the torso harness (See MWLD Task 3) and test again. If still no alarm, report on DA Form 2402, and replace the torso harness.

3. Ask Controller to test your helmet harness by firing a "near miss". When he fires, your alarm should sound briefly. You must be wearing your helmet during this test.

NOTE

If no alarm, make sure that the bottom of the harness overhangs the entire rim of the helmet and test again. If still no alarm, remove and reinsert the same battery and test again. If still no alarm, replace the battery in the helmet harness (See MWLD Task 3) and test again. If still no alarm, ask a soldier whose MWLD has already been checked and is operating properly to put on your helmet and test again. If still no alarm, report on DA Form 2402, and replace the helmet harness. If the alarm sounds, report on DA Form 2402, and replace your torso harness.

TASK 2 TEST. Test MILES System

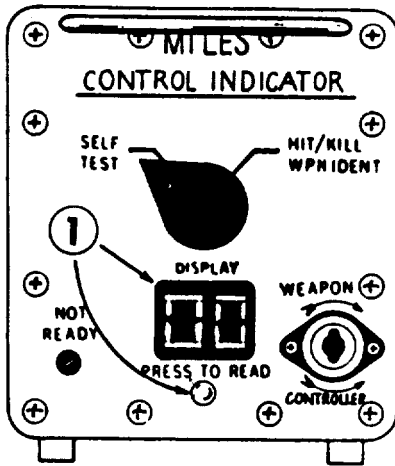

1. Push "PRESS TO READ" button on control indicator. Display should show 00.

NOTE

If display does NOT show 00, go to page 48.

2. Ask Controller to reset the system by inserting his green key in key receptacle on control indicator. Turn to CONTROLLER ON. Turn back and remove key.
3. Turn indicator switch to HIT/KILL WPN IDFN. Then turn to SELF TEST. Push "PRESS TO READ" button. Display should show 88.

NOTE

If display does NOT show 88, go to page 48.

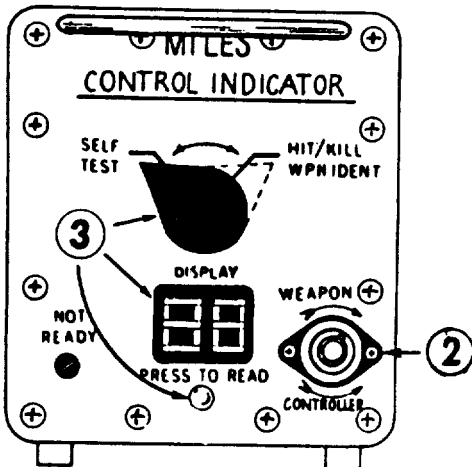

4. With vehicle master switch ON, insert the orange weapon key into control indicator and turn to WEAPON. Verify that a tone sounds in the vehicle's intercom and that the CVKI flashes continuously.

NOTE

If CVKI does not flash continuously, ask Controller to check out the equipment using the Vehicle Test Set.

TASK 2 TEST

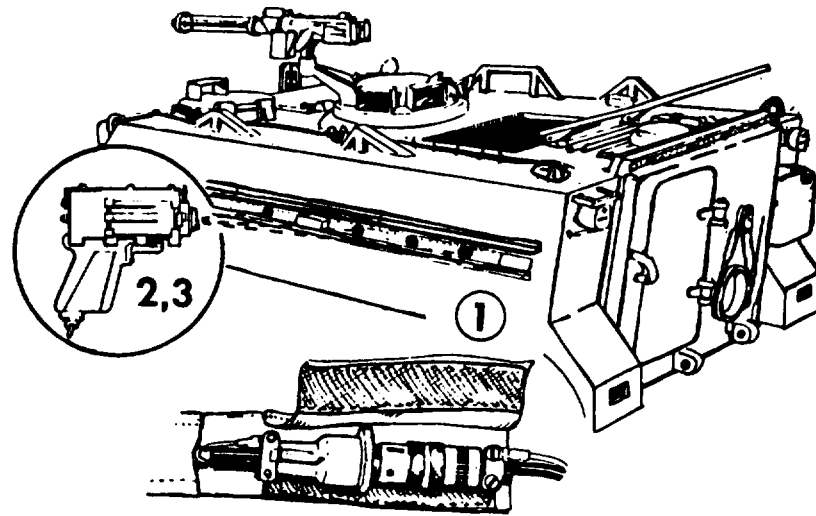

TEST DETECTOR BELT SEGMENTS:

1. First, check that all cable connections to the detector belt segments are tight. Ask a crewmate to check that the CVKI cable connections to the control indicator and the dome light are also tight.
2. Ask the Controller to test your belt segments by aiming the controller gun at a detector and firing in the "near miss" mode. Each time he fires, the CVKI vehicle light should flash. If the light never flashes, go to page 48.
3. Next, test each of the belt segments by firing at all of the detectors, one at a time. If the CVKI light does not flash for some or all of the detectors, go the page 48.
 - It is OK for one detector on each belt segment to be bad.
4. When all belt segments are working, you are through with this task.

TASK 2 TEST.

TROUBLESHOOTING PROCEDURES:

No 00

1. If the display shows a number other than 00 or is blank:
 - A. Disconnect and reconnect cable connectors labeled CONTROL CONSOLE and BATTERY.
 - Check for 00 by pushing PRESS TO READ button on control indicator.
 - If display shows 00, go back to Step 2 on page 46.
 - B. If display is still blank, ask Controller to check out the equipment by using the Vehicle Test Set.

No 88

1. If the display does not show the number 88:
 - A. Turn console switch to HIT/KILL WPN IDENT and back to SELF TEST.
 - If display shows 88, go back to Step 2 on page 46.
 - B. If display still does not show 88, ask Controller to check out the equipment using the Vehicle Test Set.

FAULT DETECTOR BELT SEGMENTS

1. Check cable connections at the detector belt segments.
2. If detector belt segments are still faulty, ask Controller to check out the equipment using the Vehicle Test Set.

TASK 1 ALIGN. Align M2 Machine Gun

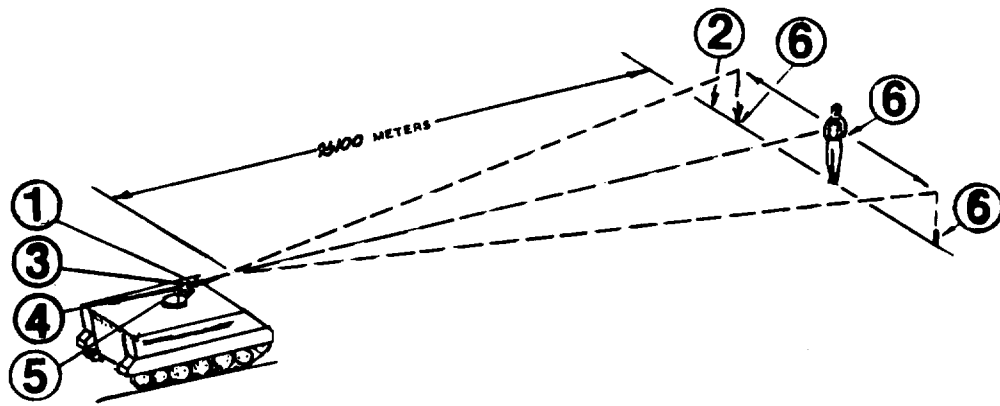

The M2 transmitter must be aligned in the "dry fire" mode, using the dry fire trigger cable. Ask the Controller for a trigger cable and, if necessary, instructions for installing and using it.

To align the M2 machine gun transmitter, you will need a soldier wearing a working MWLD. Make sure that a 9-volt battery is installed in the M2 transmitter.

1. Connect the trigger cable to the receptacle on the rear of the M2 transmitter. Ask the Controller to use his green key to start the system.
2. Position the target soldier about 100 meters away from the machine gun. The target soldier should have a green Controller's key inserted in his MWLD receptacle, turned to the "on" position. This will allow the MWLD to be continuously fired on and will give only a "near miss" indication.
3. Set the M2 machine gun sights to zero windage and 500 range. Insert an orange weapon key in the M2 transmitter receptacle.
4. As you move the gun around to aim at the target soldier, have someone assist you by holding the gun barrel steady. This is necessary because of the added weight of the blank fire adapter. Also have your assistant fire the gun by repeatedly pressing the button on the dry fire cable.
5. Move the gun around until you are pointing at the target soldier and he signals that he is receiving a "near miss" indication. When the soldier first signals, stop moving the gun and hold it in that position.
6. Have the target soldier side step to his left until he no longer hears a "near miss" indication. Have him mark that spot on the ground. Next, have the target soldier side step to his right until he no longer hears the signal, and have him mark that spot on the ground. Then position him halfway between the two spots. Without moving the gun, adjust the windage until you are aiming at the center of the target soldier's body.

TASK 1 ALIGN.

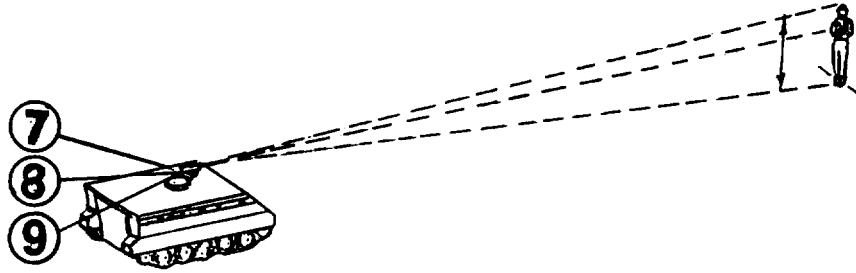

7. Next, depress the gun and aim at the target soldier's feet. Slowly move your aim up the soldier's body while firing. When the soldier first signals that he hears a "near miss" indication, stop the gun and hold it in that position. Remember the point where the gun is aimed. Continue walking the gun up the soldier's body until it points over his head and the soldier signals that he no longer hears the signal. Estimate a position halfway between where the soldier gave his two signals, and move the gun to point to this position.
8. Stabilize the gun with the help of the assistant and, without moving the gun, adjust the sight elevation so that you are aiming at the center of the target soldier's chest. Have the assistant stop firing.
9. Verify the alignment of the sights by having the soldier move to a new position. Instruct him to remove the green key from his torso harness receptacle. Once he does this, aim your sights at the center of the soldier's chest, and have the assistant fire the gun. If you "kill" the soldier, the gun is aligned correctly. Remove trigger cable assembly and screw protective cover on the transmitter receptacle.

TASK 1 OPER. Observe Your Target

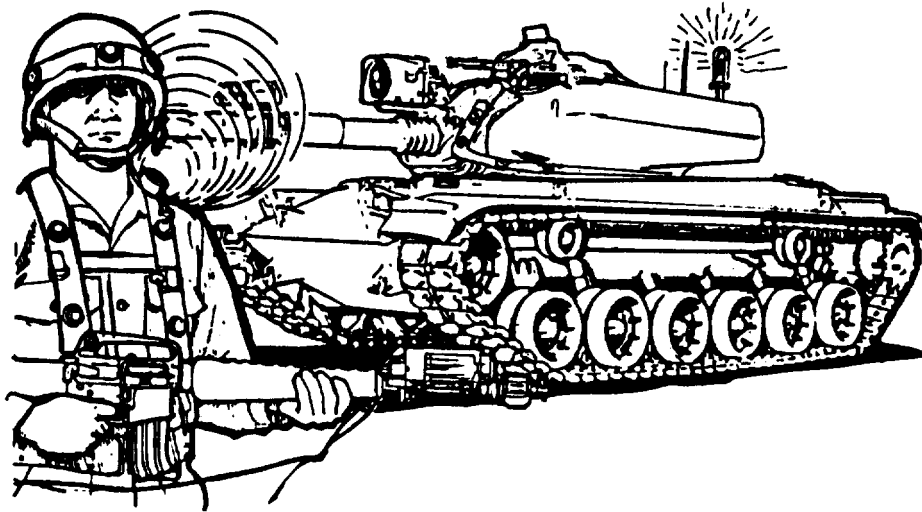

- When detectors are hit by laser fire, the CVKI light on top of the target vehicle will flash and the personnel MWLD alarm will sound. Usually you will not be close enough to hear the personnel alarm, but you should be able to see the vehicle CVKI light.
- If the shot was a "near miss", the CVKI light will flash two or three times.
- If a target vehicle is "hit" but not "killed", the CVKI light will flash four to six times.
- If the target vehicle was "killed", the CVKI will light flash continuously.
- If personnel are "killed", their MWLD alarm will sound continuously.

TASK 2 OPER. Recognizing Enemy Fire

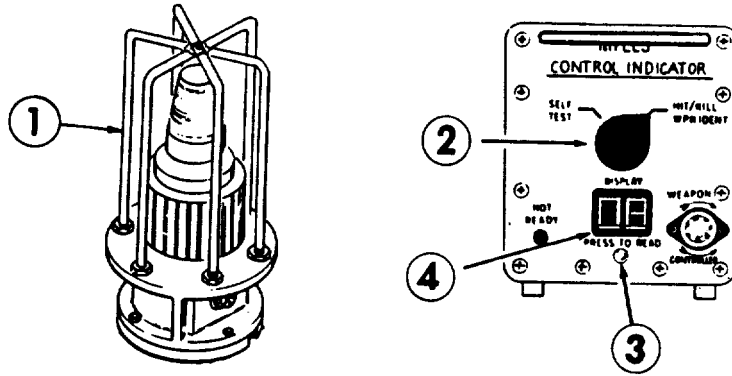

1. If your vehicle is hit by laser fire, the CVKI light will begin to flash. You will also hear an alarm beep in the intercom unit. Four beeps mean a "HIT", two beeps mean a "NEAR MISS", and a continuous tone means a "KILL" .
2. To determine what kind of weapon has fired on you, turn the switch on the control indicator to the HIT/KILL WPN IDENT position.
3. Push the "PRESS TO READ" button.
4. The display will show a number. Use the chart below to match the number on the display with the type of weapon firing on you.

Weapon Number	Weapon
00	Controller Gun
07	TOW or Shillelagh
08	DRAGON
12	105 mm
13	152 mm
15	VIPER
24	M2 or M85 Machine Gun
99	Self-kill

NOTE

If your console displays codes other than those above, call a Controller immediately.

5. "Self-Kill" results when the orange vehicle key is put in the control indicator when you have not been "killed" by laser fire. When the key is inserted and turned to WEAPON position, the 99 will be displayed and the CVKI light will flash continuously. When key is removed, a continuous tone will be heard in the intercom. You must then call the Controller to reset your system.

TASK 3 OPER. Reset After a 'Kill'

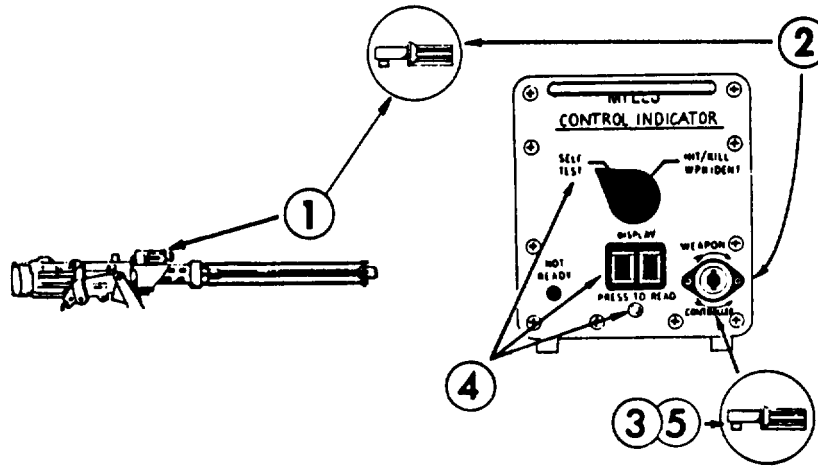

1. To silence your alarm after a "KILL", remove the orange key from the M2 machine gun transmitter. THE M2 TRANSMITTER WILL NO LONGER FIRE.
2. Insert the orange key in the control indicator and turn off the intercom alarm. If you remove the key from the control indicator, your intercom alarm will begin operating again.
3. The CVKI continues to -flash until turned off by Controller.
4. To reset: Remove orange weapon key. Intercom alarm sounds and CVKI light will continue to flash. Ask Controller to use his green key to turn them off. This resets system.
5. Turn control indicator switch to HIT/KILL WPN IDENT position then turn to SELF-TEST. Press the DISPLAY button. The display should read 88. If not 88, follow troubleshooting procedures on page 48.
6. Put your orange key back in the M2 transmitter and turn it to WEAPON ON.

NOTE

The Controller will determine when to reset your system.

TASK 4 OPER. Turn Off and Reset MWLD Alarm

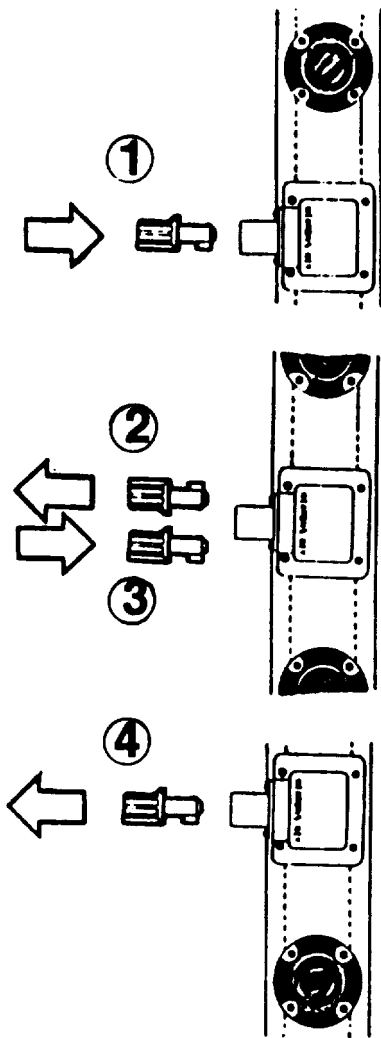

To turn off alarm:

1. Insert yellow weapon key in receptacle on torso harness. Turn off alarm.

To reset alarm, you must call the Controller.

2. Remove yellow weapon key from receptacle. (Alarm will sound).
3. Ask Controller to put green Controller key in and turn off alarm.
4. Ask Controller to remove green key. Alarm is reset.

TASK 5 OPER. Remove, Inspect, Service and Return all MILES Equipment

Use the checklist below to do this task. If you need help doing a step, refer to the tasks listed beside it.

Outside tasks:

1. Remove and inspect CVKI cable assembly. See Outside Tasks 8 and 9. (Do this after Inside Task has been done.)
2. Remove and inspect the CVKI. See Outside Tasks 6 and 7.
3. Remove and inspect detector belt segments and brush guards. Leave the Velcro tape on the vehicle. See Outside Tasks 3 and 5.

M2 MG Tasks:

1. Remove the M2 transmitter. See MG Task 3.
2. Remove the battery from the M2 transmitter and close battery compartment door. See MG Task 2.
3. Inspect and service M2 MG transmitter. See MG Task 1.
4. Remove, inspect, and service M2 MG blank firing attachment.

Inside Tasks:

1. Remove and inspect MILES inside cables. See Inside Task 5.
2. Remove battery box. Remove batteries from battery box and inspect battery box. See Inside Tasks 3 and 4.
3. Remove and inspect control indicator. See Inside Tasks 1 and 2.

MWLD Tasks:

1. Remove MWLD harnesses. See MWLD Tasks 4 and 5.
2. Remove batteries from MWLD harnesses and close battery doors. See MWLD Task 3.
3. Inspect and service the MWLD. See MWLD Tasks 1 and 2.

Return all MILES equipment and unused blank ammunition to your NCOIC. You may be asked to return your MILES equipment to its transit case. If so, follow the instructions on the next page.

TASK 5 OPER

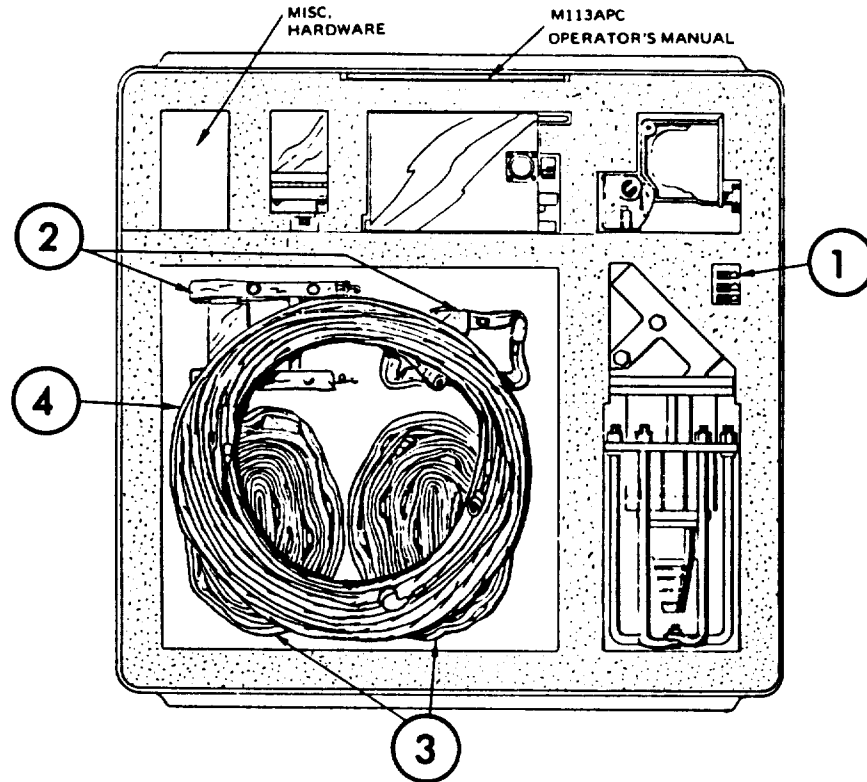

Transit Case Loading Instructions:

1. Place weapon and MWLD keys in space provided.
2. Fold up the MWLD torso and helmet harnesses and place them in the space provided.
3. Roll up the four detector belts and place them next to the MWLD harnesses.
5. Roll up the cable assembly and place it on top of the detector belts and MWLD harnesses.
6. Return the remaining MILES equipment to their proper places as shown on the drawing above.

Pack the 12 brush guard rails in their separate case.

APPENDIX A

REFERENCES

A-1. SCOPE

This appendix lists all forms, field manuals, and technical manuals referenced in this manual.

A-2. FORMS

SF 368	Quality Deficiency Report
DA Form 2028-2	Recommended Changes to Equipment Technical Publications
DA Form 2062	Hand Receipt
DA Form 2402	Exchange Tag
DA Form 2404	Equipment Inspection and Maintenance Work Sheet

A-3. FIELD MANUALS

FM 21-11	Field Manual: First Aid for Soldiers
----------	--------------------------------------

A-4. TECHNICAL MANUALS

Operator's Manual: M2 Machine Gun	TM 9-6920-12&P
TM9-1265-368-10-2	Operator's Manual: MILES Simulator System, Firing, Laser: M64 for TOW Weapon System.
TM9-1425-470-12	Operator's & Organizational Maintenance Manual for TOW Heavy Anti-Tank Assault Weapon System.
TM9-1265-370-10-3-HR	Hand Receipt for Simulator System, Firing Laser: M63 for M113/M220 APC.

A-5. MISCELLANEOUS PUBLICATIONS

AR 310-2	Identification and Distribution of DA Publications
SB 11-6	Dry Battery Supply Data
DA PAM 738-750	The Army Maintenance Management System (TAMMS)

APPENDIX B

COMPONENTS OF END ITEM AND BASIC ISSUE ITEMS LISTS

SECTION I. INTRODUCTION

This appendix lists integral components of the M113 APC and M220 TOW/MILES system. All these items, except for the expendable items in the Installation Kit, must be returned to the NCOIC following a training exercise.

Explanation of Columns:

National Stock Number:	Stock requisition number.
Description:	Lines 1 and 2 give a brief item description. Line 3 lists the Federal Supply Code for Manufacturer (FSCM) and the part number.
U/M:	Unit of Measure
Qty:	Quantity of item furnished for each piece of equipment.
Illustration:	Shows where to find an illustration of the item.

SECTION II. COMPONENTS OF END ITEM

National Stock Number	Description FSCM & Part Number	U/M	Qty	Illustration
1265-01-075-4889	M2 Machine Gun Laser Transmitter Assembly (19200) 11748803	ea.	1	1
1265-01-077-6393	Control Indicator (19200) 11749488	ea.	1	2
*	CVKI Adapter (19200) 11749728-1	ea.	1	3

*Not available at time of publication

National Stock Number	Description FSCM & Part Number	U/M	Qty	Illustration
1265-01-075-4905.	Detector Belt Assembly Segment Number 1 (19200) 11749230	ea.	2	4
1265-01-075-4907	Detector Belt Assembly Segment Number 2 (19200) 11749238	ea.	2	5
1265-01-079-4261	Installation Kit (19200) 11749421	ea.	1	6
1265-01-076-6539.	Adapter Set (19200) 11748817	ea.	1	7
1265-01-075-4893	Man Worn Laser Detector Assembly (19200) 11748808	ea.	1	8
*	Battery Box (19200) 11749790	ea.	1	9

*Not available at time of publication

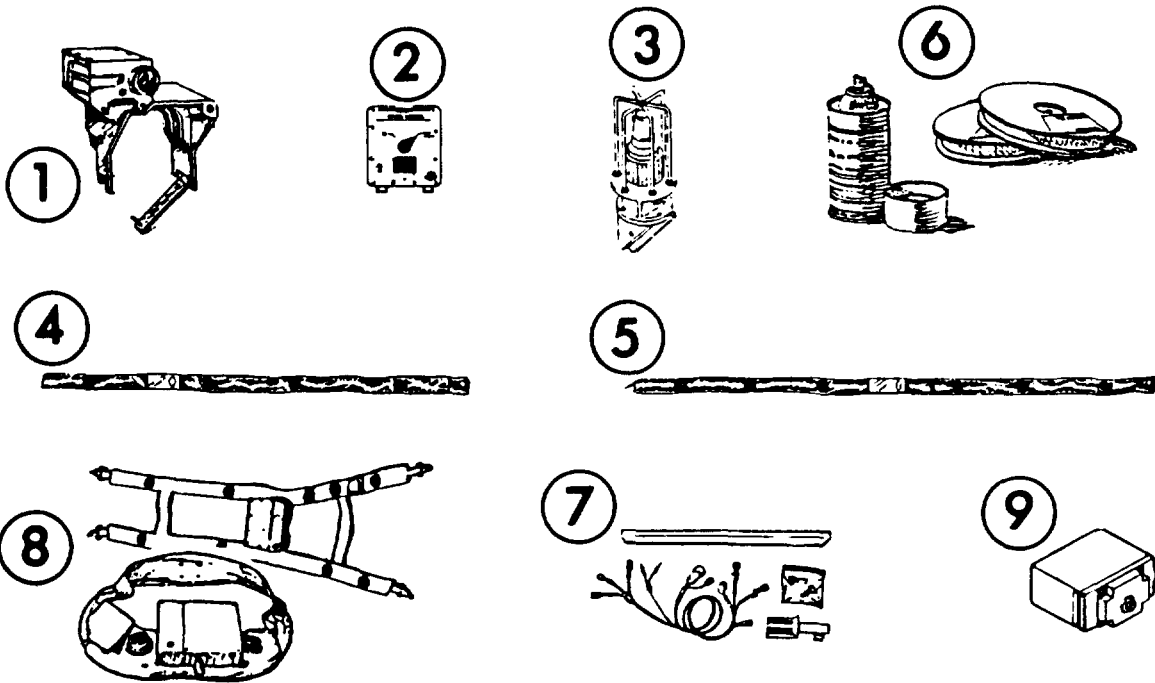

SECTION III. BASIC ISSUE ITEMS

1 ea. TM 9-1265-370-10-3

Operator's Manual f/ Simulator System, Firing Laser: M63 f/ M113 APC and M220 Tow Vehicle

APPENDIX C

ADDITIONAL AUTHORIZATION LIST

This appendix lists additional items you will need to operate the M113 APC and M220 TOW/MILES system.

Explanation of Columns:

National stock numbers, descriptions, unit of measure, and quantities are provided to help you identify and request the additional items you will need to operate the M113 APC and M220 TOW/MILES system.

National Stock Number	Description FSCM & Part Number	U/M	Qty
6135-01-063-1978	*Battery, 9 volt (80058) BA-3090/U	ea.	3
**	*Battery, 6 volt	ea.	2

*Dry battery listed is used with the equipment. It will not be shipped automatically but is to be requisitioned in quantities necessary for the particular organization in accordance with SA 11-6.

**Not available at time of publication

APPENDIX D

SPECIAL TOOLS AND TEST EQUIPMENT

This appendix lists the special tools and test equipment used with the M113 APC and M220 TOW/MILES system.

Explanation of Columns:

National stock numbers and descriptions are provided to help you identify and request the special tools and test equipment used with the M113 APC and M220 TOW/MILES system.

National Stock Number	Description FSCM & Part Number	Illustration
5120-00-243-9401	Hand Roller	Page 10

APPENDIX E

EXPENDABLE SUPPLIES AND MATERIALS LIST

This appendix lists the expendable supplies and materials you will use to operate and maintain the M113 APC/MILES system.

Explanation of Columns:

National stock numbers, descriptions, unit of measure, and quantities are provided to help you identify and request the expendable supplies and materials you will need to operate and maintain the M113 APC/MILES system.

National Stock Number	Description FSCM & Part Number	U/M	Qty
8315-01-111-7170	Velcro Tape (19200) 11749428	roll	1
8010-01-040-0947	Tape Primer (19200) 11749034	16 oz.	1
6640-00-240-5851	Paper, Lens (81349) NNN-P-40	pk.	1

REFERENCE INFORMATION

This section includes the nomenclature cross reference list, list of abbreviations, and explanations of terms (glossary) used in this manual.

A. NOMENCLATURE CROSS REFERENCE LIST

<u>Common Name</u>	<u>Official Nomenclature</u>
Brush Guard	Guard, Brush Assembly
Controller Gun	Controller's Gun, Simulator System, Laser.
Control Indicator	Console, Simulator System, Laser: for M113 APC.
CVKI	Indicator Simulator System Laser: For M113APC.
Detector Belts Segments	Detector Belt Assembly, Segment No. 1 and Segment No. 2.
Helmet Harness	Detector Assembly, Simulator System, laser: Man Worn.
M2 Machine Gun Transmitter	Transmitter Assembly, Simulator System, Laser: For M2 Machine Gun.
Torso Harness	Detector Assembly, Simulator System, Laser: Man Worn.

B. LIST OF ABBREVIATIONS

CVKI	Combat Vehicle Kill Indicator.
MILES	Multiple Integrated Laser Engagement System.
MWLD	Man Worn Laser Detector.

C. GLOSSARY

Control Indicator	The MILES device used to turn equipment on/off.
Controller	The umpire or referee in a MILES training exercise.
Controller Gun	The device used to test MILES detector systems. May also be used to disqualify soldiers or vehicles from an exercise.

Controller Key	The green key used by the Controller to reset MILES transmitters.
Combat Vehicle Kill Indicator	The MILES device attached to armored vehicles to provide external flashing light to indicate that the vehicle has been "killed".
Hit	A beep alarm in intercom and flashing light repeated four to six times means your vehicle has been hit by laser fire.
Kill	In a MILES training exercise, a continuous alarm in intercom and continuous flashing light indicates the detector assembly was hit by a laser beam. The orange weapon key is removed from the machine gun transmitter and put in the control indicator to silence the alarm. The machine gun transmitter will not operate with key removed.
Laser Beam	In MILES a harmless invisible beam of light which simulates weapon fire.
Laser Detector Assembly beam directed at it.	A device which senses the laser
Laser Transmitter	A device that sends the laser beam.
Man Worn Laser Detector beam directed at it.	The device which senses the laser
Near Miss	An intercom alarm and flashing light repeated two times indicates laser fire directed toward you.

Orange Key

This orange key has two uses:

1. Turns on the M2 machine gun transmitter.
2. When continuous intercom alarm sounds and light flashes, remove from M2 transmitter and put in the control indicator to turn off intercom alarm.

Simulator

A training device which takes the place of real equipment and which has many of its characteristics.

Velcro Tape

A particular brand name for hook and pile fastener tape. It is used to hold vehicle detector belts and other MILES equipment in place.

Yellow Key

Carried by vehicle personnel wearing MWLDs. When continuous alarm sounds, it is put in the MWLD key receptacle to silence alarm.

By Order of the Secretary of the Army:

CARL E. VUONO
General, United States Army
Chief of Staff

Official:

R. L. DILWORTH
Brigadier General, United States Army
The Adjutant General

DISTRIBUTION:

To be distributed in accordance with DA Form 12-32, Operator's Maintenance requirements for MILES Simulator System, Firing, Laser M68 (for VIPER).

RECOMMENDED CHANGES TO EQUIPMENT TECHNICAL PUBLICATIONS

 <div style="border: 1px solid black; border-radius: 15px; padding: 5px; display: inline-block; margin-left: 20px;"> <p style="margin: 0;"><i>THEN...JOT DOWN THE DOPE ABOUT IT ON THIS FORM. CAREFULLY TEAR IT OUT, FOLD IT AND DROP IT IN THE MAIL.</i></p> </div>		SOMETHING WRONG WITH PUBLICATION	
		FROM: (PRINT YOUR UNIT'S COMPLETE ADDRESS)	
PUBLICATION NUMBER		DATE SENT	
PUBLICATION DATE		PUBLICATION TITLE	
BE EXACT PIN-POINT WHERE IT IS			
PAGE NO.	PARA- GRAPH	FIGURE NO.	TABLE NO.
<div style="border: 1px solid black; height: 400px; margin-top: 10px;"> <p style="text-align: center; font-weight: bold; margin-top: 10px;">IN THIS SPACE, TELL WHAT IS WRONG AND WHAT SHOULD BE DONE ABOUT IT.</p> </div>			
PRINTED NAME, GRADE OR TITLE AND TELEPHONE NUMBER			SIGN HERE

The Metric System and Equivalents

Linear Measure

1 centimeter = 10 millimeters = .39 inch
 1 decimeter = 10 centimeters = 3.94 inches
 1 meter = 10 decimeters = 39.37 inches
 1 dekameter = 10 meters = 32.8 feet
 1 hectometer = 10 dekameters = 328.08 feet
 1 kilometer = 10 hectometers = 3,280.8 feet

Weights

1 centigram = 10 milligrams = .15 grain
 1 decigram = 10 centigrams = 1.54 grains
 1 gram = 10 decigrams = .035 ounce
 1 decagram = 10 grams = .35 ounce
 1 hectogram = 10 decagrams = 3.52 ounces
 1 kilogram = 10 hectograms = 2.2 pounds
 1 quintal = 100 kilograms = 220.46 pounds
 1 metric ton = 10 quintals = 1.1 short tons

Liquid Measure

1 centiliter = 10 milliliters = .34 fl. ounce
 1 deciliter = 10 centiliters = 3.38 fl. ounces
 1 liter = 10 deciliters = 33.81 fl. ounces
 1 dekaliter = 10 liters = 2.64 gallons
 1 hectoliter = 10 dekaliters = 26.42 gallons
 1 kiloliter = 10 hectoliters = 264.18 gallons

Square Measure

1 sq. centimeter = 100 sq. millimeters = .155 sq. inch
 1 sq. decimeter = 100 sq. centimeters = 15.5 sq. inches
 1 sq. meter (centare) = 100 sq. decimeters = 10.76 sq. feet
 1 sq. dekameter (are) = 100 sq. meters = 1,076.4 sq. feet
 1 sq. hectometer (hectare) = 100 sq. dekameters = 2.47 acres
 1 sq. kilometer = 100 sq. hectometers = .386 sq. mile

Cubic Measure

1 cu. centimeter = 1000 cu. millimeters = .06 cu. inch
 1 cu. decimeter = 1000 cu. centimeters = 61.02 cu. inches
 1 cu. meter = 1000 cu. decimeters = 35.31 cu. feet

Approximate Conversion Factors

<i>To change</i>	<i>To</i>	<i>Multiply by</i>	<i>To change</i>	<i>To</i>	<i>Multiply by</i>
inches	centimeters	2.540	ounce-inches	Newton-meters	.007062
feet	meters	.305	centimeters	inches	.394
yards	meters	.914	meters	feet	3.280
miles	kilometers	1.609	meters	yards	1.094
square inches	square centimeters	6.451	kilometers	miles	.621
square feet	square meters	.093	square centimeters	square inches	.155
square yards	square meters	.836	square meters	square feet	10.764
square miles	square kilometers	2.590	square meters	square yards	1.196
acres	square hectometers	.405	square kilometers	square miles	.386
cubic feet	cubic meters	.028	square hectometers	acres	2.471
cubic yards	cubic meters	.765	cubic meters	cubic feet	35.315
fluid ounces	milliliters	29.573	cubic meters	cubic yards	1.308
pints	liters	.473	milliliters	fluid ounces	.034
quarts	liters	.946	liters	pints	2.113
gallons	liters	3.785	liters	quarts	1.057
ounces	grams	28.349	liters	gallons	.264
pounds	kilograms	.454	grams	ounces	.035
short tons	metric tons	.907	kilograms	pounds	2.205
pound-feet	Newton-meters	1.356	metric tons	short tons	1.102
pound-inches	Newton-meters	.11296			

Temperature (Exact)

°F	Fahrenheit temperature	5/9 (after subtracting 32)	Celsius temperature	°C
----	---------------------------	-------------------------------	------------------------	----

